

- A.1.1** Introduction
  
- A.2** **Typical Signs & Usage**
  - A.2.1** Type 1 & 1pb – Room Signs
  - A.2.2** Type 2, 2pb & 2ss – Large Room Signs
  - A.2.3** Type 3 – Facilities Signs (All types)
  - A.2.4** Type 4 – Stair Signs
  - A.2.5** Type 5 & 5ss – Large Room & Dedication Signs
  - A.2.5.1** Type 5dy & 5dy.fp – Directory Signs
  - A.2.6** Type 6 – Hanging Directional Signs
  - A.2.7** Type 7 – Small Hanging Directional Signs
  - A.2.8** Type 8 – Department & Wall Directional Signs
  - A.2.9** Type 9 – Faculty Directory Signs
  - A.2.10** Type 10 – Wall Blade Signs
  - A.2.11** Type 11 & 11lg – Notice Holders
  
- A.3** **Assembly Details**
  - A.3.1** Type 1 & 1pb – Room Signs
  - A.3.2** Type 2 & 2pb – Large Room Signs
  - A.3.2.1** Type 2ss – Dedicated Room Signs
  - A.3.3** Type 3 – Notice Signs (All types)
  - A.3.4** Type 4 – Tactile Stair Signs
  - A.3.5** Type 5, 5dy & 5rm – Room/Area Signs
  - A.3.5.1** Type 5dy.fp – Directory Signs
  - A.3.5.2** Type 5ss – Dedicated Building/Area Signs
  - A.3.6** Type 6 – Hanging Directional Signs
  - A.3.6.1** Type 6.1 – Hanging Directional Signs
  - A.3.6.2** Type 6sq – Hanging Directional Signs
  - A.3.6.3** Type 6.3 – Hanging Directional Signs
  - A.3.7** Type 7 & 7ex – Small Hanging Directional Signs
  - A.3.8** Type 8 – Department & Wall Directional Signs
  - A.3.9** Type 9 – Faculty Directory Signs
  - A.3.10** Type 10 – Wall Blade Signs
  - A.3.11** Type 11 & 11lg – Notice Holders

- A.4**            **Sign Graphics**
- A.4.1**        Type 1 & 1pb – Room Signs
- A.4.2**        Type 2 & 2pb – Large Room Signs
- A.4.3**        Type 3 – Notice Signs – Typical Icons 1
- A.4.3.1**      Type 3 – Notice Signs – Typical Icons 2
- A.4.3.2**      Type 3 – Notice Signs – Special Icons
- A.4.3.3**      Type 3 – Notice Signs – Text Notices (Typical)
- A.4.4**        Type 4 – Tactile Stair Signs
- A.4.5**        Type 5 – Large Room & Directory Signs
- A.4.6**        Type 6 – Hanging Directional Signs
- A.4.7**        Type 7 – Small Hanging Directional Signs
- A.4.8**        Type 8 – Department & Wall Directional Signs
- A.4.9**        Type 9 – Faculty Directory Signs – Blade Art
- A.4.10**      Type 10 – Wall Blade Signs
- A.4.11**      Type 11 – Notice Holders
  
- A.5**            **Installation Details**
- A.5.1**        Type 1 & 1pb – Room Signs
- A.5.2**        Type 2 & 2pb – Large Room Signs
- A.5.3**        Type 3 – Facilities Signs (All types)
- A.5.4**        Type 4 – Stair Signs
- A.5.5**        Type 5 & 5ss – Large Room & Dedication Signs
- A.5.5.1**      Type 5dy & 5dy.fp – Directory Signs
- A.5.6**        Type 6 – Hanging Directional Signs
- A.5.7**        Type 7 – Small Hanging Directional Signs
- A.5.8**        Type 8 – Department & Wall Directional Signs
- A.5.9**        Type 9 – Faculty Directory Signs
- A.5.10**      Type 10 – Wall Blade Signs
- A.5.11**      Type 11 & 11lg – Notice Holders
  
- A.6**            **Maintenance**
- A.6.1**        Interior Signage – Maintenance

## **General Notes on Interior Signage:**

These are the Carleton University Interior Signs as of 2008.

### **Section A.2 (Usage):**

This section will aid in the appropriate selection of the sign(s) for the desired purpose.

### **Section A.3 (Details):**

This section provides general information on the manufacture and installation of the sign(s). This is to be supplemented by the interior signage production drawings, included in the appendices of this package.

### **Section A.4 (Graphics)**

This section gives the font usage, size and location guidelines for laying out text and icons for the various signs.

### **Section A.5 (Installation Heights and Locations)**

This section is to be used in conjunction with section A.3 to install the signs. Signs should only be installed by qualified (signage) technicians.

### **Section A.6 (Maintenance)**

This section provides recommendations for cleaning and dealing with vandalism.

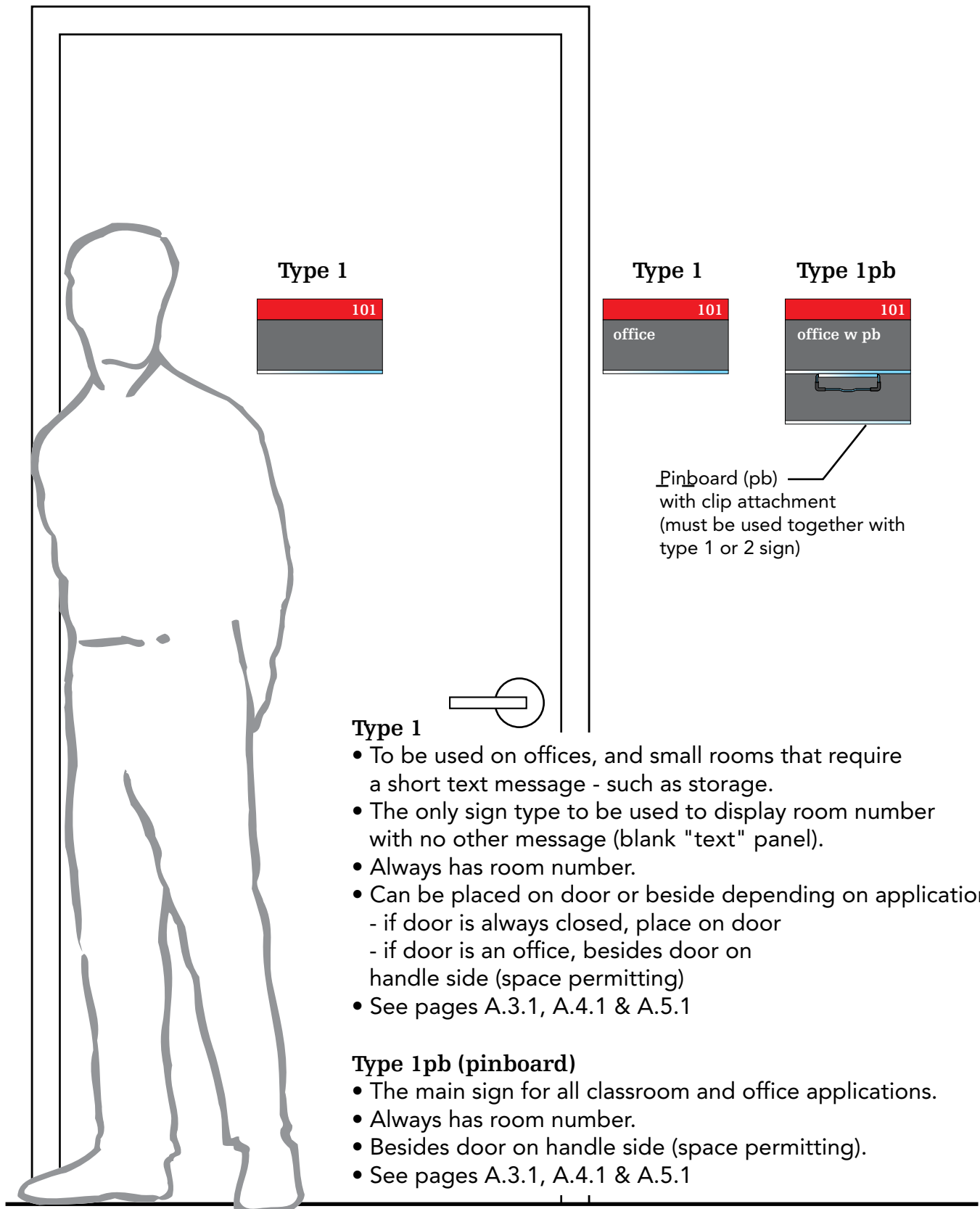

# Type 2, 2pb & 2ss

## Large Room Signs

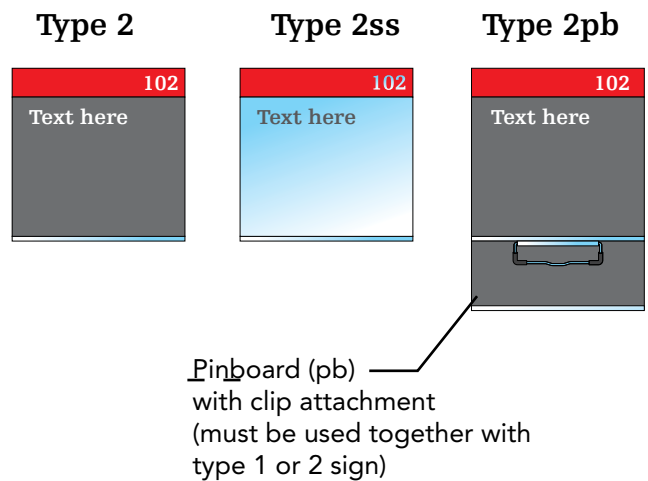
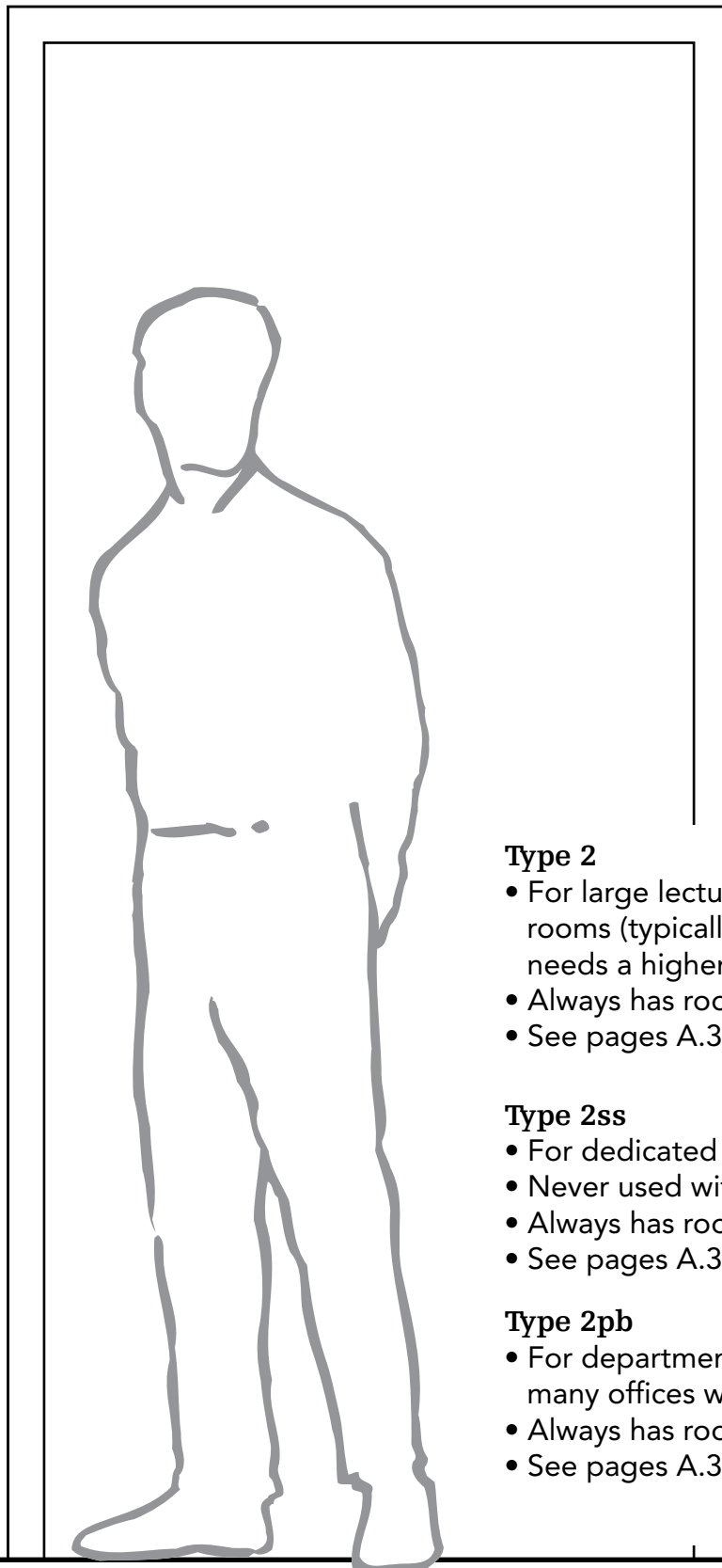

### Type 2

- For large lecture theatres, departmental doors and special rooms (typically with many offices within; or a function that needs a higher profile)
- Always has room number.
- See pages A.3.2, A.4.2 & A.5.2

### Type 2ss

- For dedicated rooms.
- Never used with a pinboard.
- Always has room number.
- See pages A.3.2.1, A.4.2 & A.5.2

### Type 2pb

- For departmental doors and special rooms (typically with many offices within; or a function that needs a higher profile)
- Always has room number.
- See pages A.3.2, A.4.12 & A.5.2

## Facilities Signs (All types)

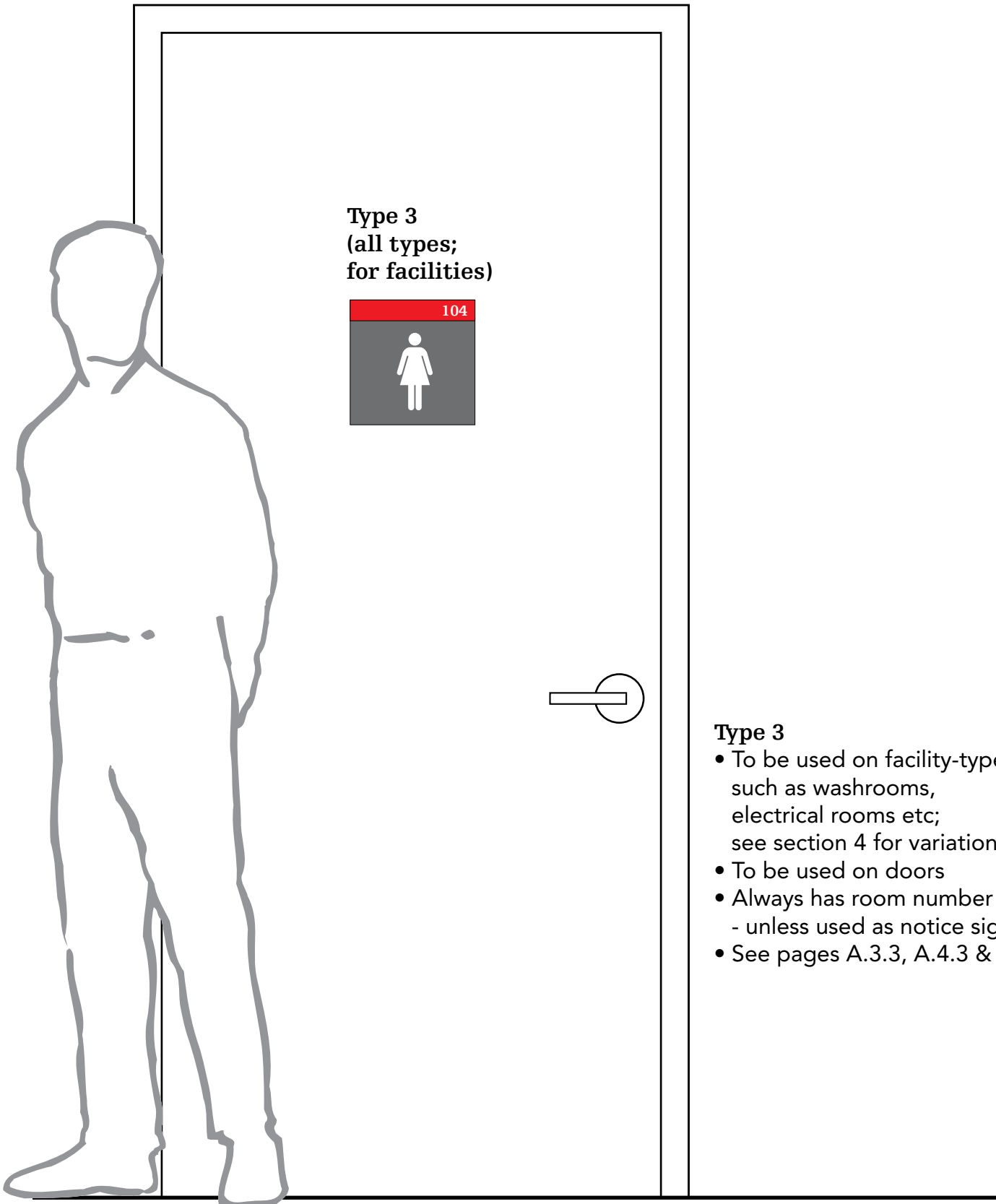

Type 3  
(all types;  
for facilities)

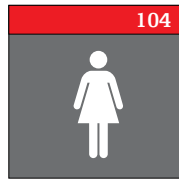

### Type 3

- To be used on facility-type rooms; such as washrooms, electrical rooms etc; see section 4 for variations
- To be used on doors
- Always has room number - unless used as notice sign
- See pages A.3.3, A.4.3 & A.5.3

# Type 4 Stair Signs

## A.2.4

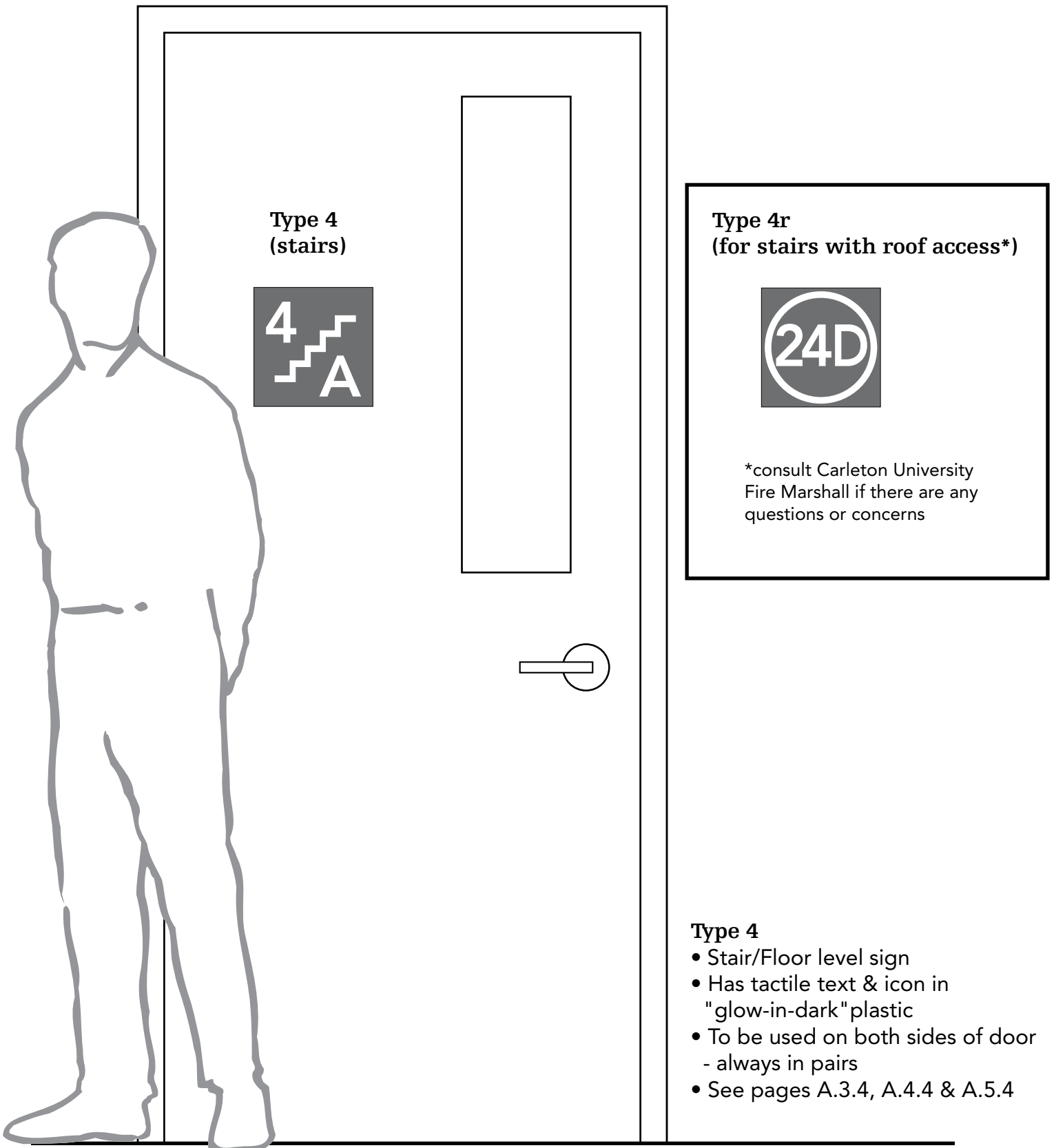

- Type 4**
- Stair/Floor level sign
  - Has tactile text & icon in "glow-in-dark" plastic
  - To be used on both sides of door - always in pairs
  - See pages A.3.4, A.4.4 & A.5.4

## Large Room & Dedication Signs

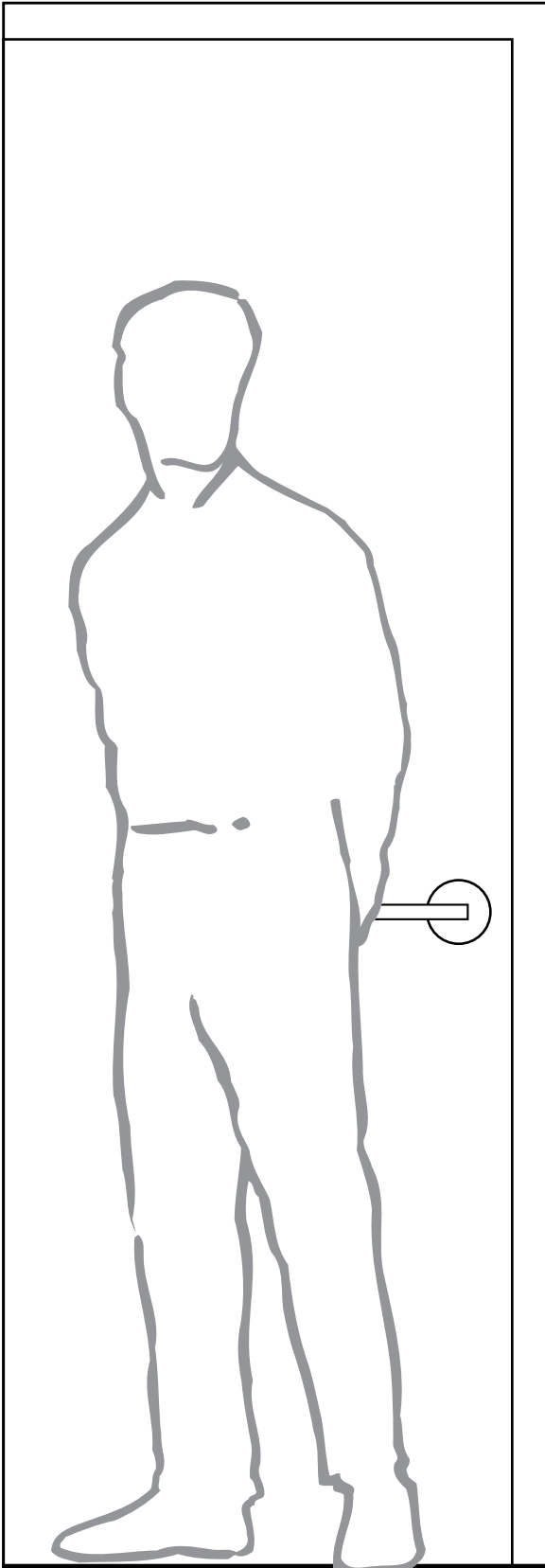

**Type 5  
(also 5rm)**



**Type 5ss  
(Stainless steel for  
Building Dedication)**



**Type 5 (also 5rm)**

- Used as large room sign or directory
- Room sign - must have room number; mounted on handle side of door.
- See pages A.3.5, A.4.5 & A.5.5

**Type 5ss**

- For building dedication
- See pages A.3.5.2, A.4.5 & A.5.5



# Type 5dy & 5dy.fp

## Directory Signs

# A.2.5.1

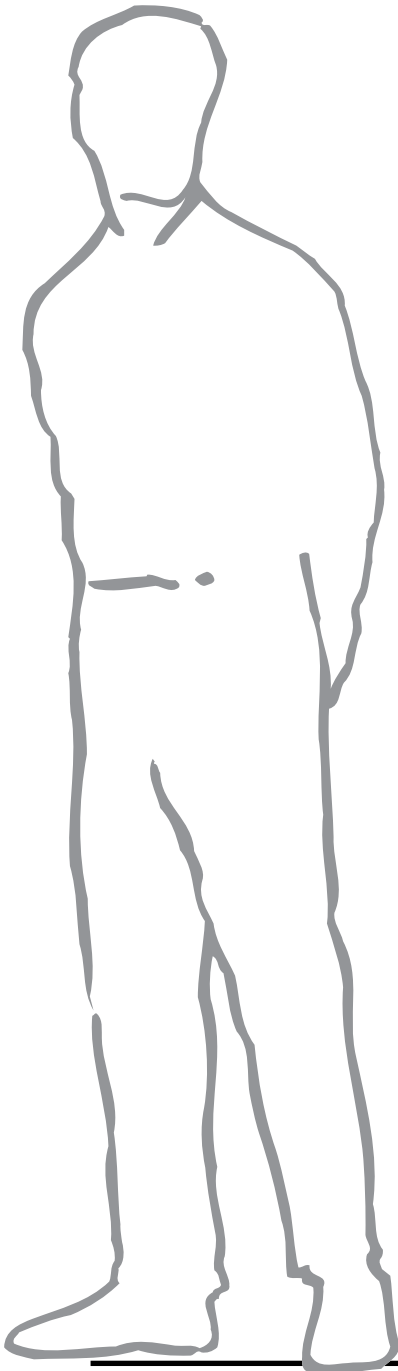

Type 5dy

Level 3	
LEVEL	LEVEL
1 Art Gallery Reader's Digest Resource Centre Lecture Theatre Washrooms	3 Canada NewsWire Newsroom Centretown News CIJ Survey Centre Journalism Main Office Office of the Director Office of the School Administrator Radio News Wilfrid Eggleston Room
2 Art Gallery	4 Art History Graduate Students Audio-Visual Resource Centre Film Studies Graduate Students Harold A. Morrison Room School of Studies in Arts and Culture Secretariat Student Lounge

Type 5dy.fp

Level 3	
LEVEL	LEVEL
1 Art Gallery Reader's Digest Resource Centre Lecture Theatre Washrooms	3 Canada NewsWire Newsroom Centretown News CIJ Survey Centre Journalism Main Office Office of the Director Office of the School Administrator Radio News Wilfrid Eggleston Room
2 Art Gallery	4 Art History Graduate Students Audio-Visual Resource Centre Film Studies Graduate Students Harold A. Morrison Room School of Studies in Arts and Culture Secretariat Student Lounge

Floorplan (fp)  
insert holder  
- for 11x17 laserprinted  
inserts

### Type 5dy (directory)

- Directory - must have level number; must be mounted with minimum of 6" clearance on both sides.
- See pages A.3.5.1, A.4.5 & A.5.5.1

### Type 5dy.fp (directory with floorplan)

- Directory - must have level number; must be mounted with minimum of 6" clearance on both sides.
- Floorplan Holder - accepts 11x17 laserprinted inserts.
- See pages A.3.5.1, A.4.5 & A.5.5.1

## Hanging Directional Signs



**Type 6**



**Type 6.1**

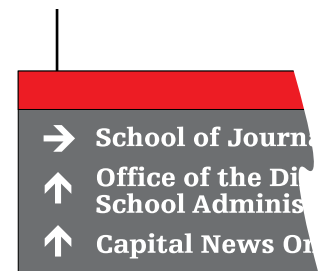

**Type 6sq**

**& Type 6.3**

### Type 6

- Double-sided directional sign
- Can be single-sided if hung 6" (or less) from wall or mounted directly to wall.
- Can list 4 (minimum) to 6 (maximum) different listings with directional arrows.
- See pages A.3.6, A.4.6 & A.5.6

### Type 6.1 (single blade)

- Double-sided directional sign
- Can be single-sided if hung 6" (or less) from wall or mounted directly to wall.
- Can only list one item with or without directional arrow.
- See pages A.3.6.1, A.4.6 & A.5.6

### Type 6sq

- 4 sided (cube) sign
- Can be three sided if hung 6" (or less) from wall.
- Can list 1 to 3 (maximum) items per side.
- See pages A.3.6.2, A.4.6 & A.5.6

### Type 6.3

- Double-sided directional sign
- Can be single-sided if hung 6" (or less) from wall or mounted directly to wall.
- Can list 1 to 3 (maximum) items per side.
- See pages A.3.6.3, A.4.6 & A.5.6

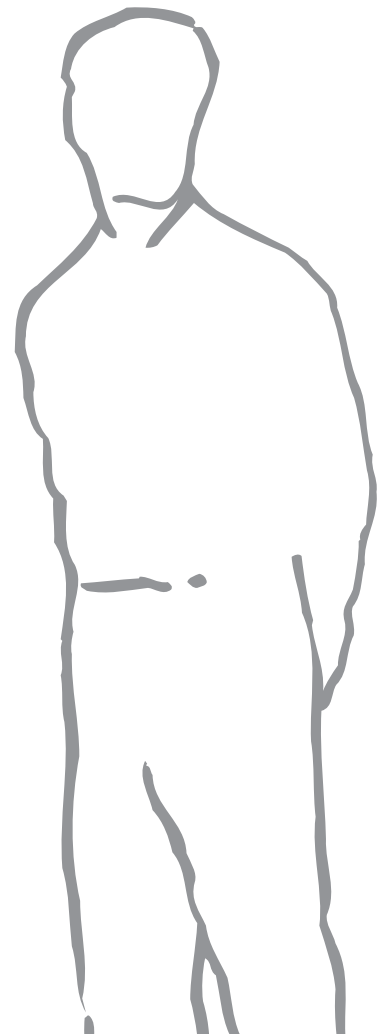

## Small Hanging Directional Signs

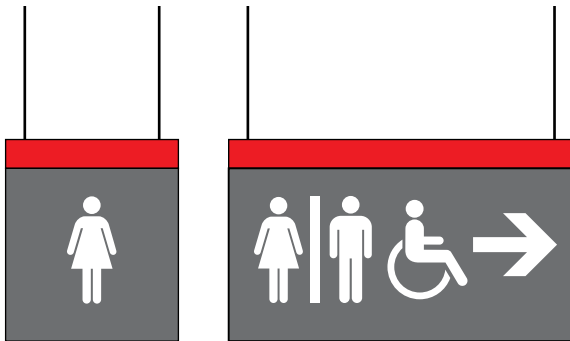

Type 7

Type 7ex

### Type 7 & 7ex

- Double-sided icon directional signs
- Can be single-sided if hung 6" (or less) from wall or mounted directly to wall.
- Type 7 can have only 1 icon
- Type 7ex can have 2 icons (maximum) plus arrow.
- See pages A.3.7, A.4.7 & A.5.7

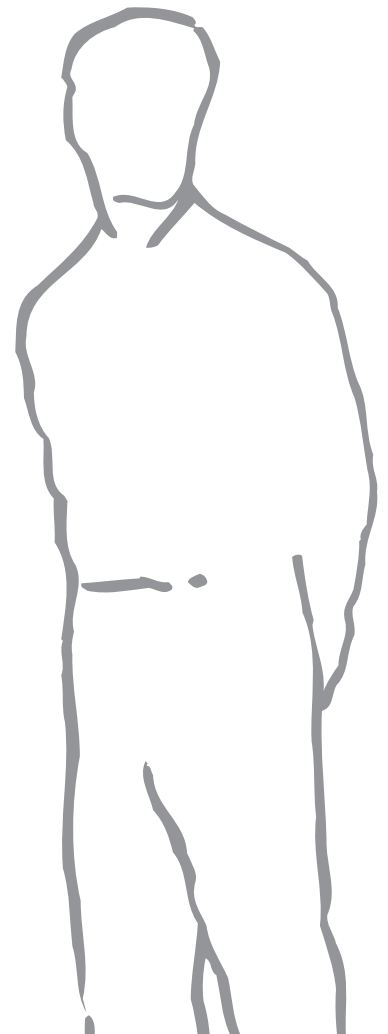

## Department & Wall Directional Signs

Type 8 (also 8dl, 8rm)

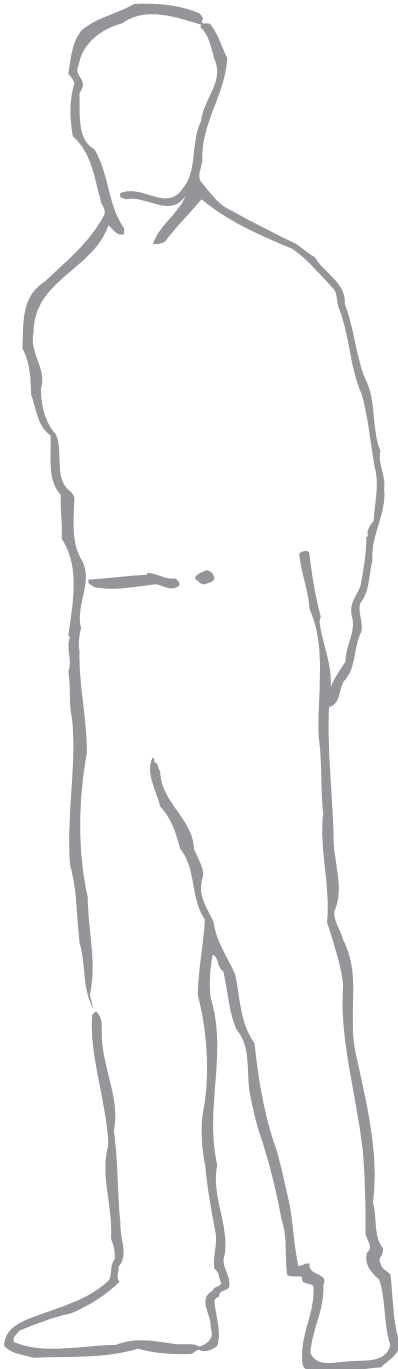

### Type 8 (Also 8dl & 8rm)

- Wall-mounted Directional sign & Departmental sign
- Directional Sign - wall-mounted alternative for use in areas where ceiling height precludes use of type 6 sign, acrylic layer on type 8 protects vinyl text (type 6 text is easily vandalised).
- Departmental Sign - for use at building/lobby entrances (see 3.4.8 "Graphics Section" for examples)
- See pages A.3.8, A.4.8 & A.5.8

## Faculty Directory Signs

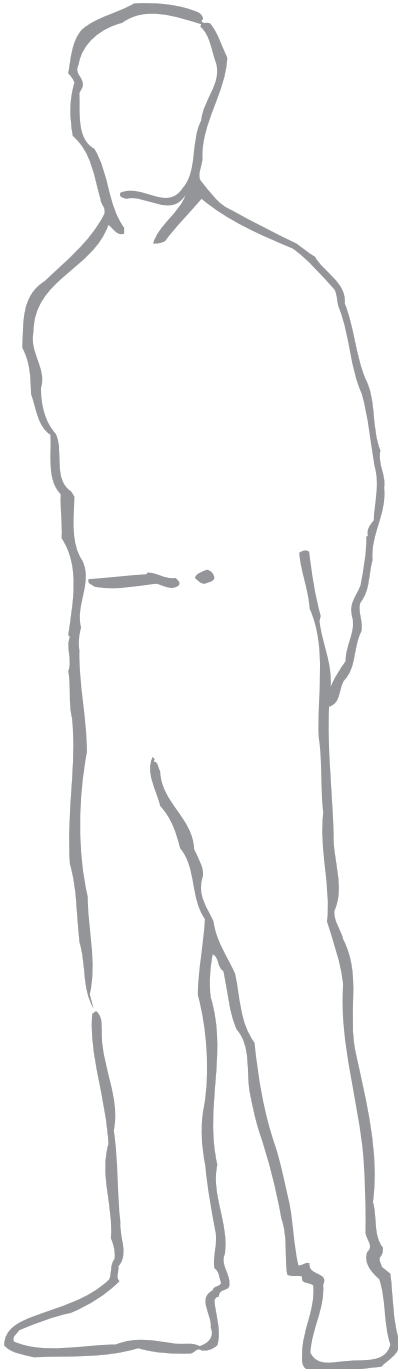

**Type 9**  
**(also 9bu, 9fa)**  
**Faculty Directory**

**Type 9**

- Wall-mounted Faculty Directory
- With changeable blades.
- Can have Header in white vinyl.
- For use at Faculty lobby areas & elevator lobbies.
- See pages A.3.9, A.4.9 & A.5.9

## Wall Blade Signs

Type 10  
(\*10mw, 10 fw,  
10mh etc.)

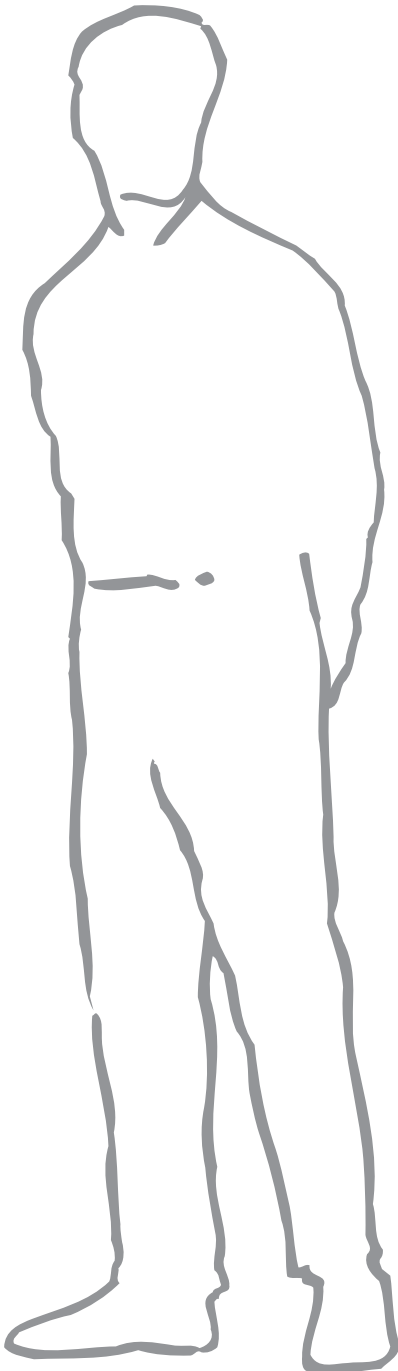
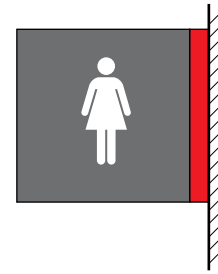

### Type 10

- Wall-mounted single blade single icon sign.
- Mounted perpendicular to wall
- For use at washrooms, elevators and other facilities to help identify rooms - when ceiling height is inappropriate for type 7.
- See pages A.3.10, A.4.10 & A.5.10

\*note: letters indicate icon, eg: 10mw is men's washroom - see graphics section A.4.3

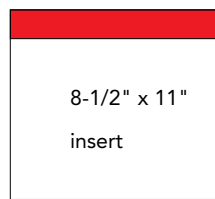
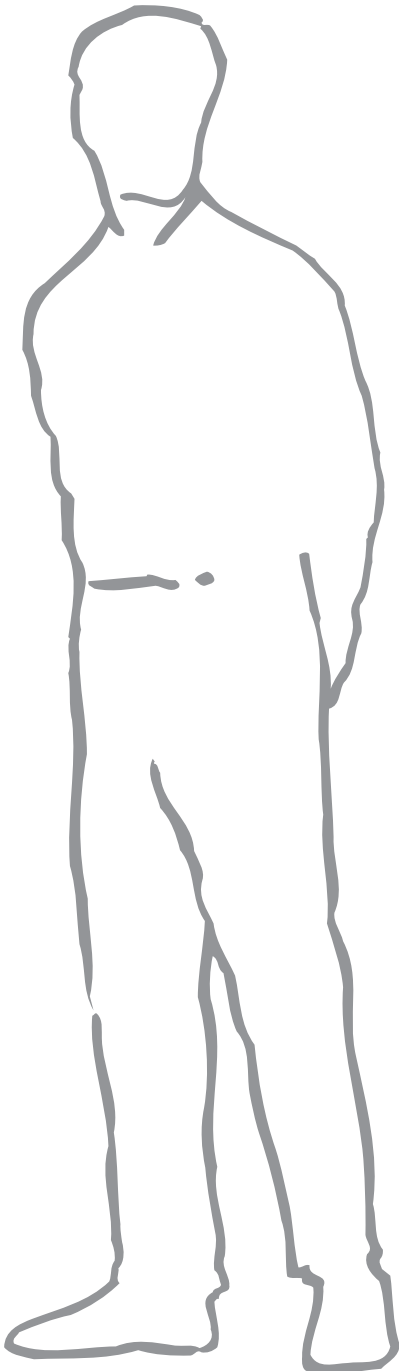

**Type 11**

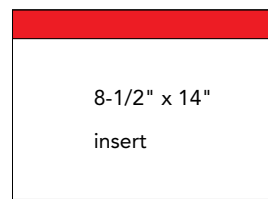

**Type 11lg**

### **Type 11**

- Insert holders for laserprinted paper
- Type 11 - for letter size inserts:  
for classroom size/layout inserts and  
other areas where user changeable  
text is required (ie seasonal hours or  
holiday hours)
- Type 11lg - for legal size inserts:  
mainly for fire evacuation plans.
- See pages A.3.11, A.4.11 & A.5.11

# Type 1 & 1pb Room Signs

## A.3.1

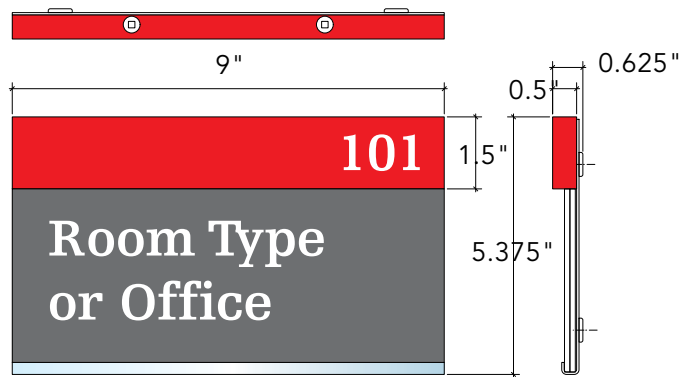

Type 1 Sign

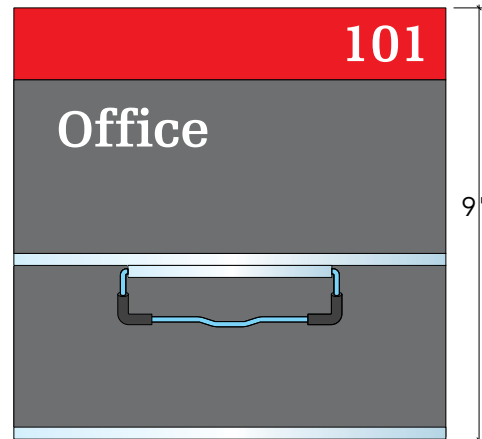

Type 1pb Sign

### MATERIALS:

- 18 gauge stainless steel
- 1/8" acrylic – P99 – painted dark gray on back
- 1/8" acrylic – P99 (anti-glare frosting) with white vinyl on back
- 1/2" acrylic – clear – painted red on visible surfaces

for 'pb' (pinboard) part

- 18 gauge stainless steel
- dark gray pinboard material
- spring clip

### DISASSEMBLY for TEXT PANEL CHANGE:

- Remove 2 - #6 x 1" countersunk machine screws on top to remove red bar; allows 1/8" acrylic panels to be removed

### INSTALLATION:

for type 1pb:

- 1) Install 2 - #8 countersunk screws into wall (with anchors - as required) for 'pb' (note: these screws should be 7.875" below top of sign; 7" apart)
- 2) Install 'pb'; ensure keyholes are fully engaged
- 3) Install type 2 directly on top of 'pb' - see below

for type 1:

- 1) Install with 4 - #8 countersunk screws into wall (with anchors - as required) - ensure screw heads are set back into depressions far enough to not scratch paint on back of gray graphic panel
- 2) Slide gray graphic panel into place - painted surface faces wall
- 3) Slide P99 (with vinyl text) panel into place - vinyl faces wall
- 4) Place red bar over panels & onto tabs. Insert #6 screws & thread into hole. DO NOT OVER TIGHTEN

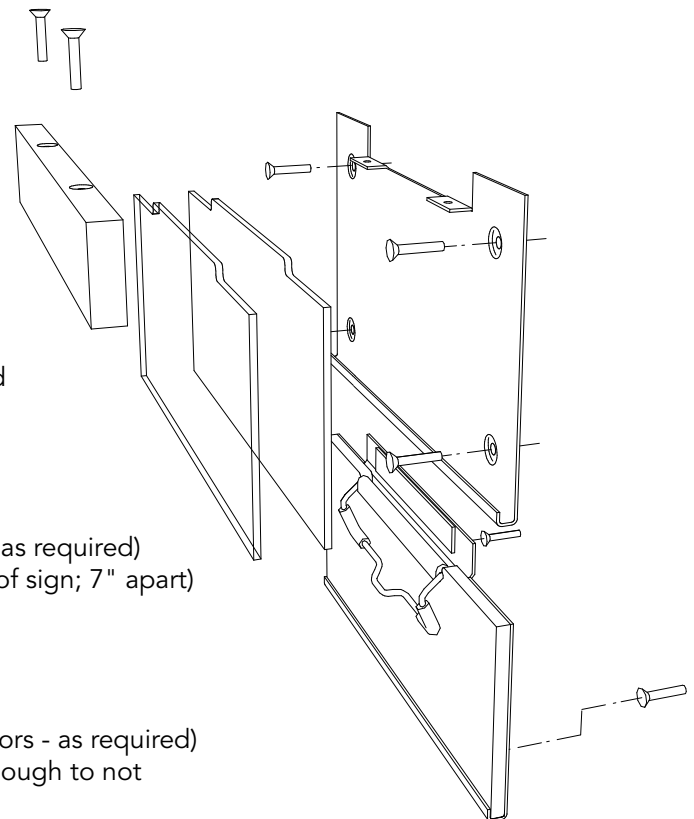

Type 1pb Sign  
– Exploded Perspective View



# Type 2 & 2pb

## Large Room Signs

# A.3.2

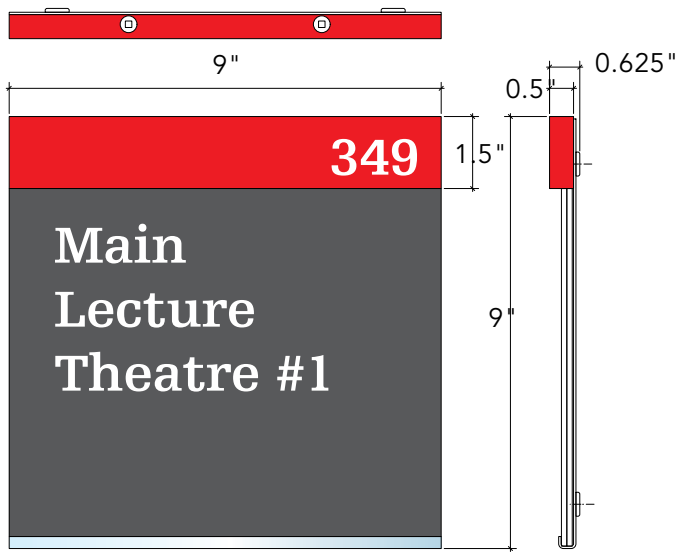

**Type 2 Sign**

### MATERIALS:

- 18 gauge stainless steel
- 1/8" acrylic – P99 – painted dark gray on back
- 1/8" acrylic – P99 (anti-glare frosting) with white vinyl on back
- 1/2" acrylic – clear – painted red on visible surfaces

for 'pb' (pinboard) part

- 18 gauge stainless steel
- dark gray pinboard material
- spring clip

### DISASSEMBLY for TEXT PANEL CHANGE:

- Remove 2 - #6 x 1" countersunk machine screws on top to remove red bar; allows 1/8" acrylic panels to be removed

### INSTALLATION:

for type 2pb:

- 1) Install 2 - #8 countersunk screws into wall (with anchors - as required) for 'pb' (note: these screws should be 11.5" below top of sign; 7" apart)
- 2) Install 'pb'; ensure keyholes are fully engaged
- 3) Install type 2 directly on top of 'pb' - see below

for type 2:

- 1) Install with 4 - #8 countersunk screws into wall (with anchors - as required) - ensure screw heads are set back into depressions far enough to not scratch paint on back of gray graphic panel
- 2) Slide gray graphic panel into place - painted surface faces wall
- 3) Slide P99 (with vinyl text) panel into place - vinyl faces wall
- 4) Place red bar over panels & onto tabs. Insert #6 screws & thread into hole. DO NOT OVER TIGHTEN

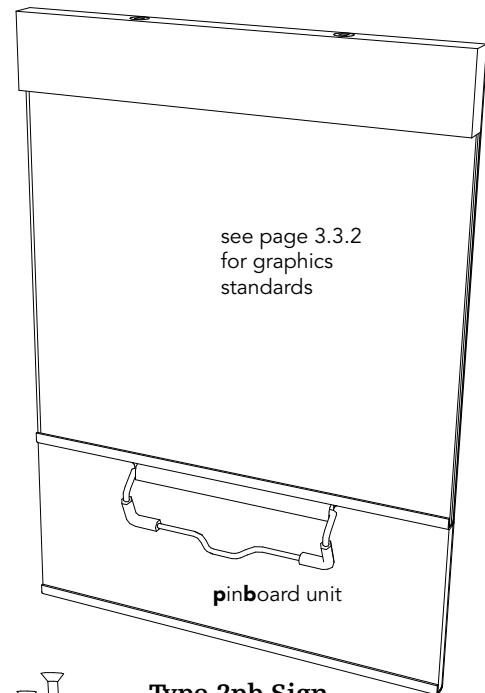

**Type 2pb Sign**

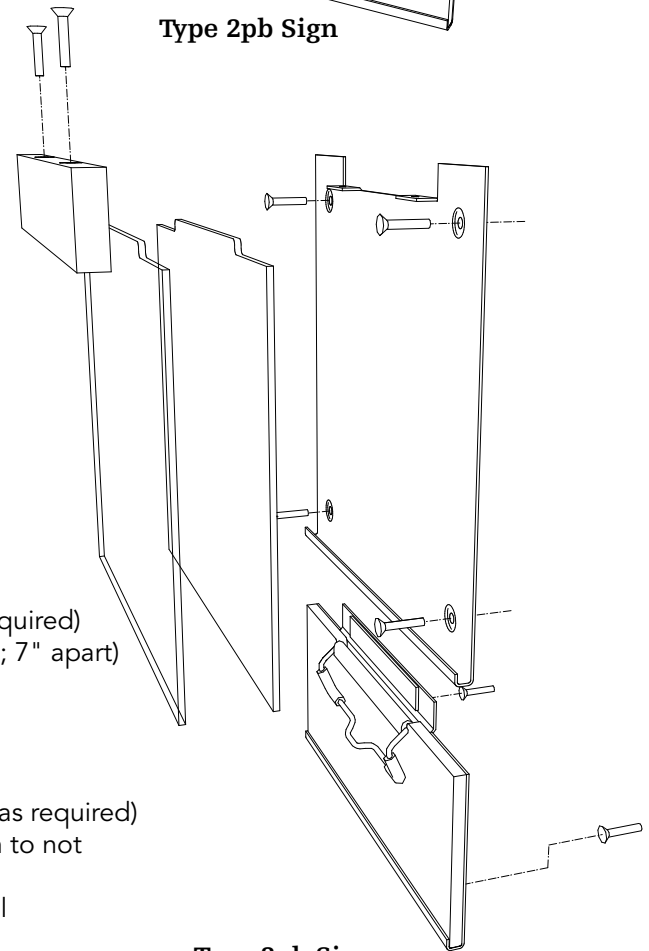

**Type 2pb Sign  
– Exploded Perspective View**

# Type 2ss

## Dedicated Room Signs

# A.3.2.1

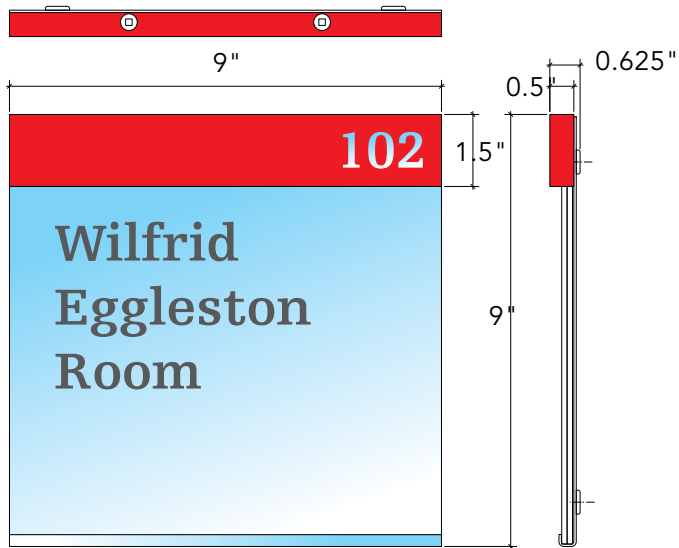

Type 2ss Sign

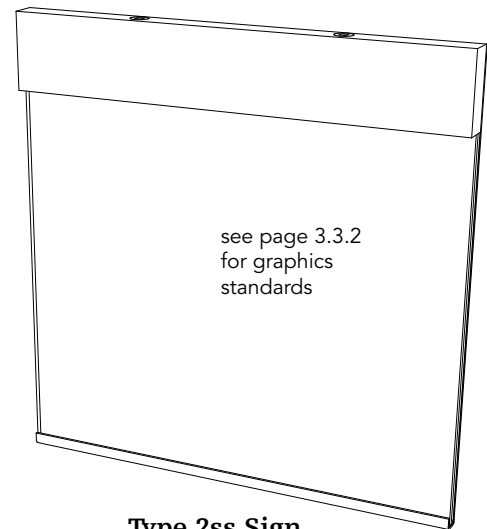

Type 2ss Sign

### MATERIALS:

- 18 gauge stainless steel
- 3/16" acrylic – clear – bonded to stainless front panel
- 20 gauge stainless steel front panel with screenprinted text (dark gray)
- 1/2" acrylic – clear – painted red on visible surfaces with inlaid room numbers in polished aluminum laminate

### INSTALLATION:

for type 2:

- 1) Install with 4 - #8 countersunk screws into wall (with anchors - as required) - ensure screw heads are set back into depressions far enough to not scratch paint on back of gray graphic panel
- 2) Slide stainless /acrylic panel into channel.
- 3) Place red bar over panels & onto tabs. Insert #6 screws & thread into hole. DO NOT OVERTIGHTEN

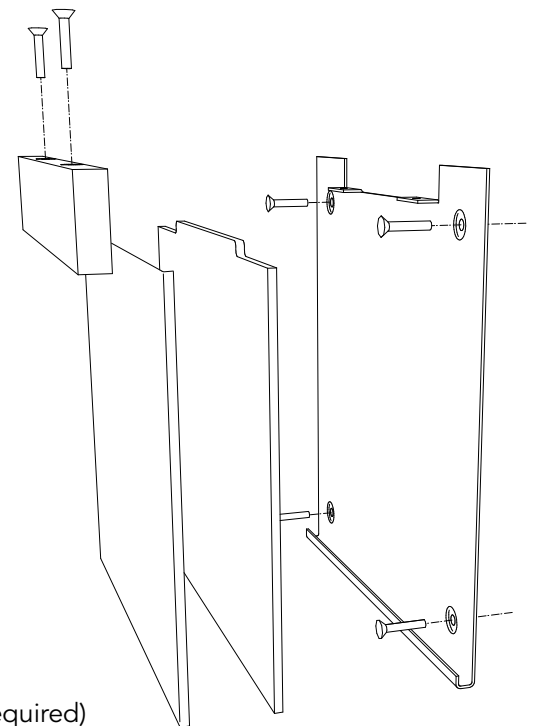

Type 2ss Sign  
- Exploded Perspective View

## Notice Signs (All types)

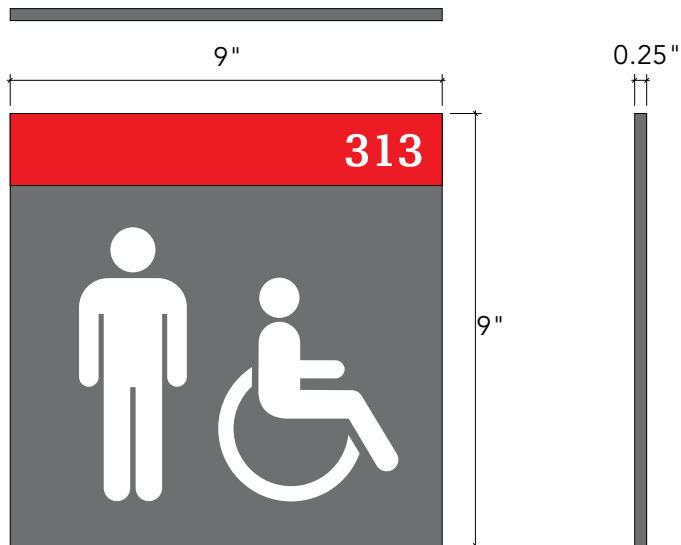

**Type 3 Sign**

### **MATERIALS:**

- 1/4" acrylic – P95 (anti-glare frosting)
  - texture faces forward
  - painted gray on back
  - painted red bar on front top
  - printed icon or text on front

### **INSTALLATION:**

- 1) Install with perimeter foamtape (inset 1/4" from all edges) 3M #4032 x 1/2" width.
- 2) Follow manufacturer's directions for surface preparation and application.

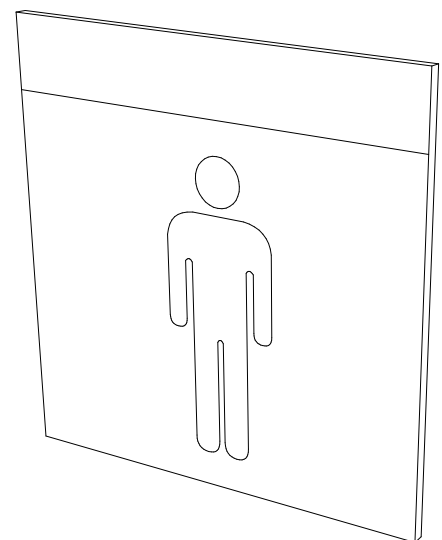

**Type 3 Sign  
– Perspective View**

# Type 4 Tactile Stair Signs

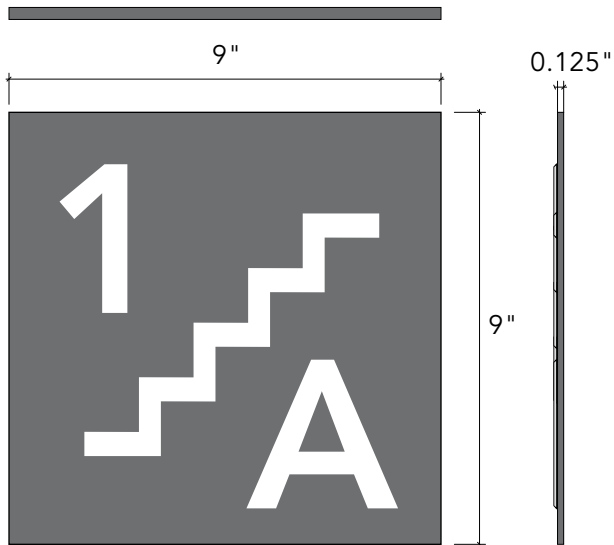

**Type 4 Sign**



## **MATERIALS:**

- 1/8" acrylic – P95 (anti-glare frosting)
  - texture faces forward
  - painted gray on back
- 1/8" glow-in-the-dark" beveled plastic set 0.040" into back (P95) panel

## **INSTALLATION:**

- 1) Install with perimeter foamtape (inset 1/4" from all edges) 3M #4032 x 1/2" width.
- 2) Follow manufacturer's directions for surface preparation and application.

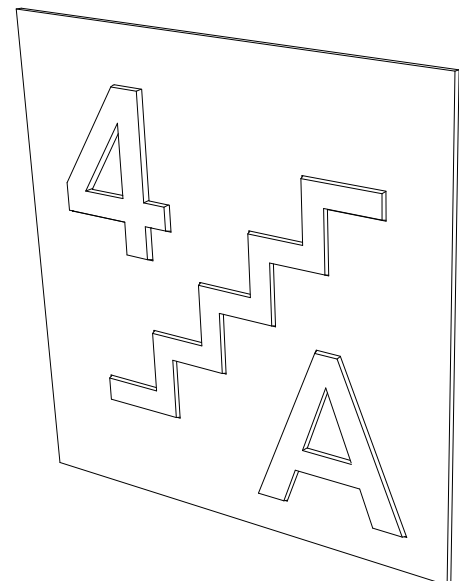

**Type 4 Sign  
– Perspective View**

# Type 5, 5dy & 5rm Room / Area Signs

## A.3.5

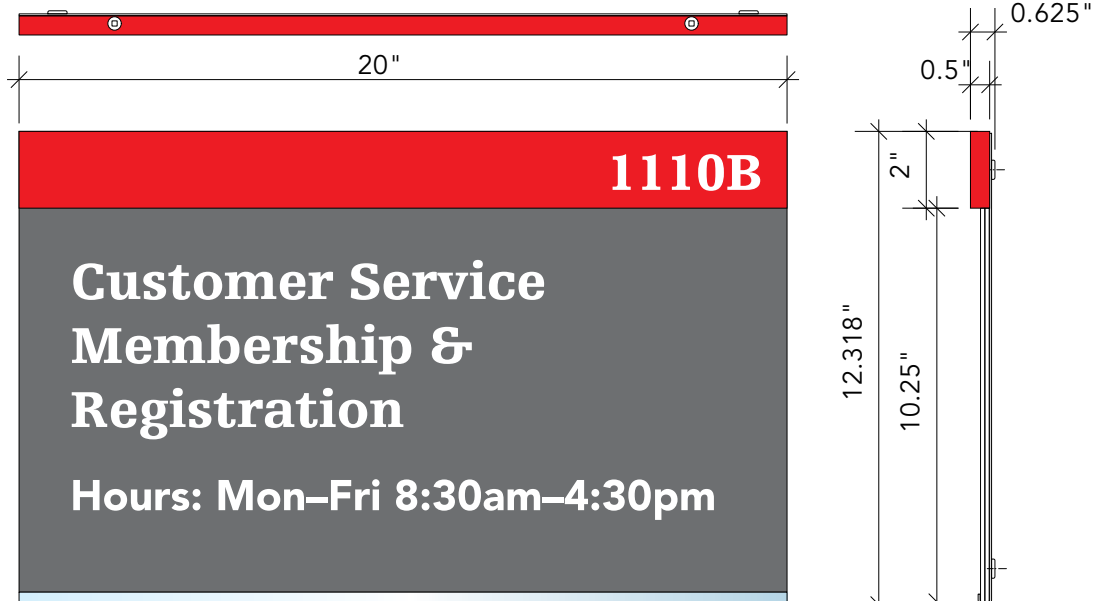

Type 5 Sign

### MATERIALS:

- 18 gauge stainless steel
- 1/8" acrylic -P99 - painted dark gray on back
- 1/8" acrylic - P99 (anti-glare frosting) with white vinyl on back
- 1/2" acrylic - clear - painted red on visible surfaces

### DISASSEMBLY for TEXT PANEL CHANGE:

- Remove 3 - #6 x 1" countersunk machine screws on top to remove red bar; allows 1/8" acrylic panels to be removed

### INSTALLATION:

- 1) Install with 4 - #8 countersunk screws into wall (with anchors - as required)
  - ensure screw heads are set back into depressions far enough to not scratch paint on back of gray graphic panel
- 2) Slide gray graphic panel into place - painted surface faces wall
- 3) Slide P99 (with vinyl text) panel into place - vinyl faces wall
- 4) Place red bar over panels & onto tabs. Insert #6 screws & thread into hole. DO NOT OVER TIGHTEN

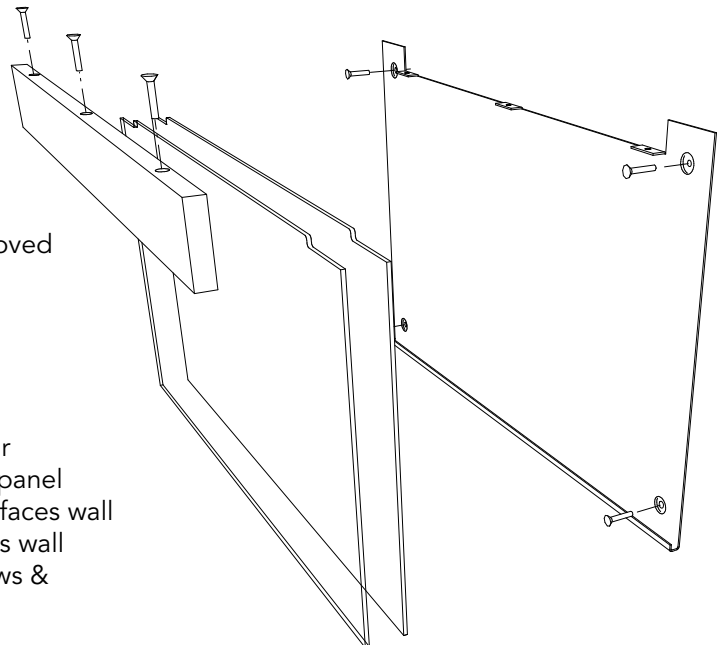

Type 5 Sign  
- Exploded Perspective View

# Type 5dy.fp Directory Signs

# A.3.5.1

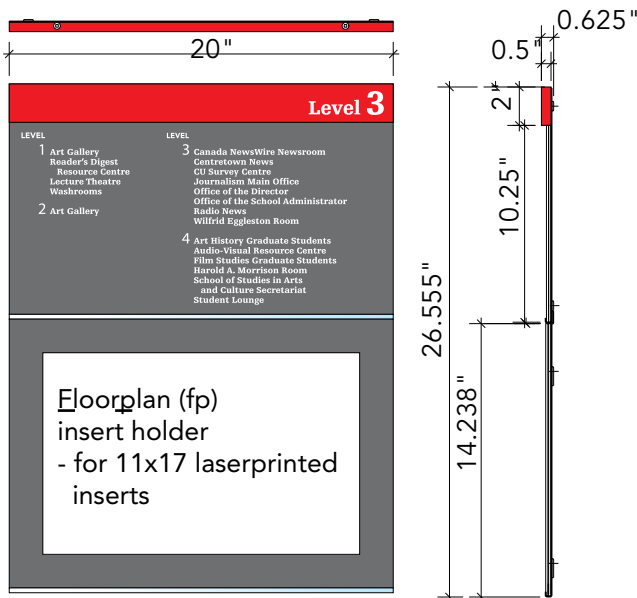

Type 5dy.fp Sign

## MATERIALS:

- 18 gauge stainless steel
- 1/8" acrylic – P99 – painted dark gray on back
- 1/8" acrylic – P99 (anti-glare frosting) with white vinyl or screen-printing on back
- 1/2" acrylic – clear – painted red on visible surfaces

for 'fp' (floorplan) part

- 18 gauge stainless steel
- 0.090" acrylic – P99 (anti-glare frosting) with gray window on back
- 1/8" acrylic – clear – painted dark gray on back

## DISASSEMBLY for TEXT PANEL CHANGE:

- Remove 3 - #6 x 1" countersunk machine screws on top to remove red bar; allows 1/8" acrylic panels to be removed

## FLOORPLAN INSERT CHANGE:

- Remove laserprinted insert by inserting "post-it" note; press on front acrylic to adhere to insert and pull out (either) side
- Alternate method:
- Insert thick card stock in either side to push insert out

## INSTALLATION:

for type 5fp:

- 1) Install 4 - #8 countersunk screws into wall (with anchors - as required) for 'fp'
- 2) Install 'fp'; ensure keyholes are fully engaged
- 3) Install type 5 directly on top of 'fp' - see below

for type 5:

- 1) Install with 4 - #8 countersunk screws into wall (with anchors - as required)
  - ensure screw heads are set back into depressions far enough to not scratch paint on back of gray graphic panel
- 2) Slide gray graphic panel into place - painted surface faces wall
- 3) Slide P99 (with vinyl text) panel into place - vinyl faces wall
- 4) Place red bar over panels & onto tabs. Insert #6 screws & thread into hole. DO NOT OVER TIGHTEN

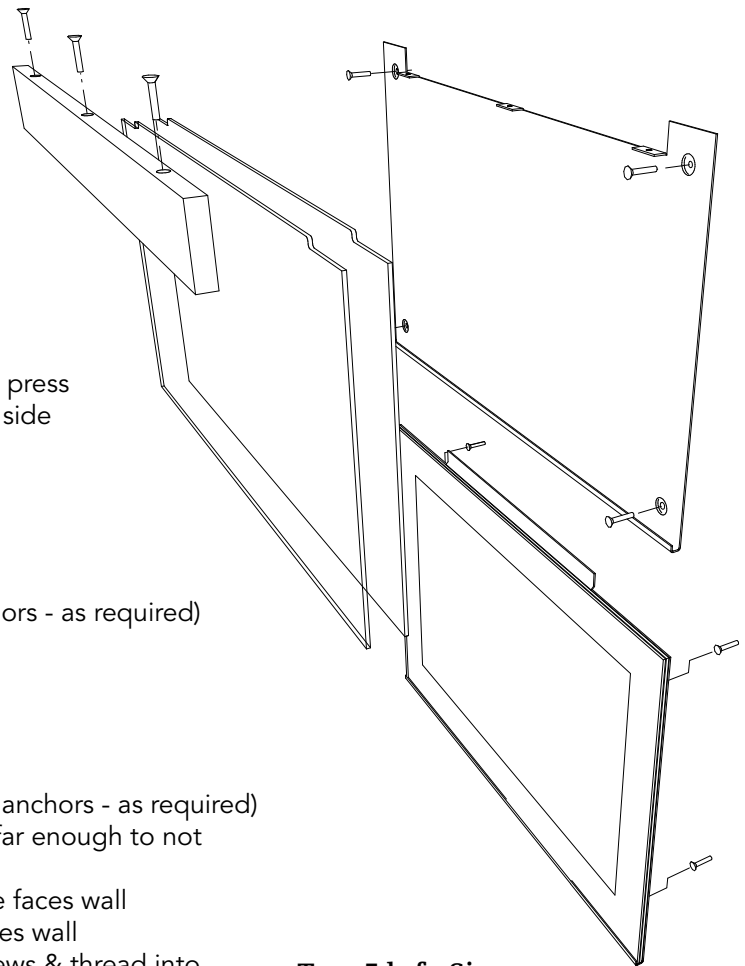

Type 5dy.fp Sign  
– Exploded Perspective View

## Dedicated Building / Area Signs



**Type 5ss Sign**

---

### MATERIALS:

- 18 gauge stainless steel
  - 3/16" acrylic – clear – bonded to stainless front panel
  - 20 gauge stainless steel front panel with screenprinted text (dark gray)
  - 1/2" acrylic – clear – painted red on visible surfaces with inlaid year numerals in polished aluminum laminate
- 

### INSTALLATION:

- 1) Install with 4 - #8 countersunk screws into wall (with anchors - as required)
  - ensure screw heads are set back into depressions far enough to not scratch paint on back of gray graphic panel
- 2) Slide stainless /acrylic panel into channel.
- 3) Place red bar over panels & onto tabs. Insert #6 screws & thread into hole. DO NOT OVERTIGHTEN

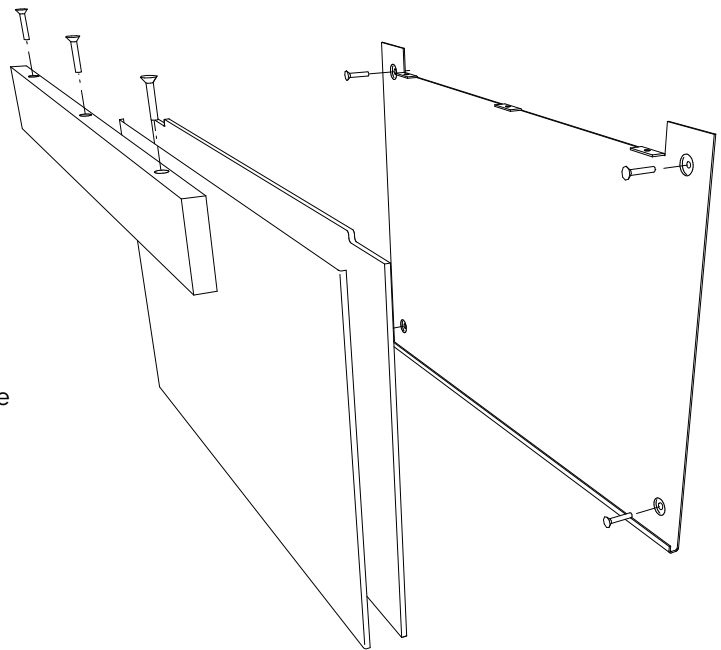

**Type 5 Sign**  
– Exploded Perspective View

## Hanging Directional Signs

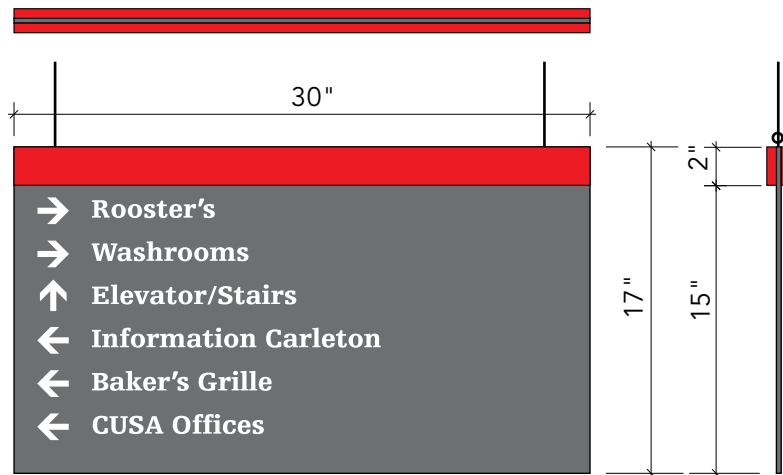

**Type 6 Sign**  
**Double-sided Hanging Directional Sign**

### MATERIALS:

- 1/4" gray 'sintra' (foamed PVC)
  - painted gray on both sides
  - white vinyl icon and text on both sides
- 1/2" acrylic – clear – painted red on visible surfaces

### INSTALLATION:

- 1) Hang from ceiling with steel cable.
  - Acoustic tile ceiling - use approved metal clip-on connector for ceiling system
  - Concrete ceiling & Drywall ceiling - use appropriate anchor with threaded eyelet

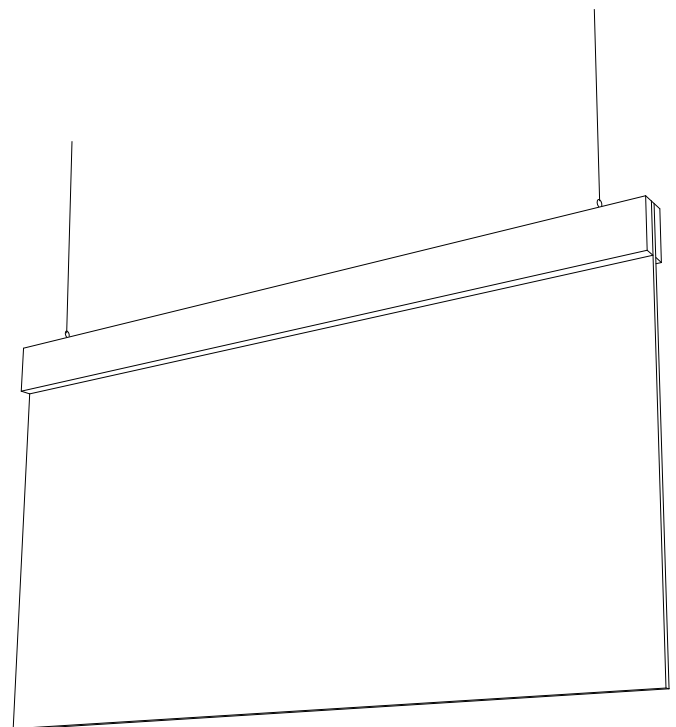

**Type 6 Sign**  
**- Perspective View**



## Hanging Directional Signs

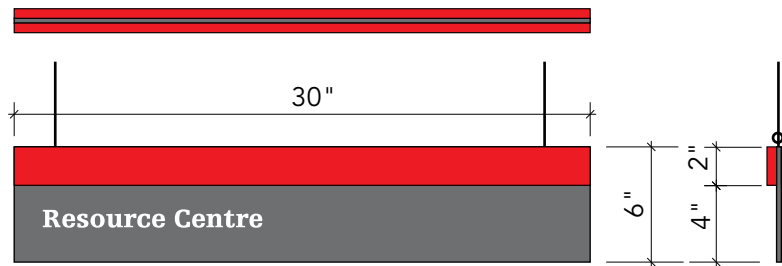

**Type 6.1 Sign**  
**Double-sided Hanging Directional Sign**

### **MATERIALS:**

- 1/4" gray 'sintra' (foamed PVC)
  - painted gray on both sides
  - white vinyl icon and text on both sides
- 1/2" acrylic – clear – painted red on visible surfaces

### **INSTALLATION:**

- 1) Hang from ceiling with steel cable.
  - Acoustic tile ceiling - use approved metal clip-on connector for ceiling system
  - Concrete ceiling & Drywall ceiling - use appropriate anchor with threaded eyelet

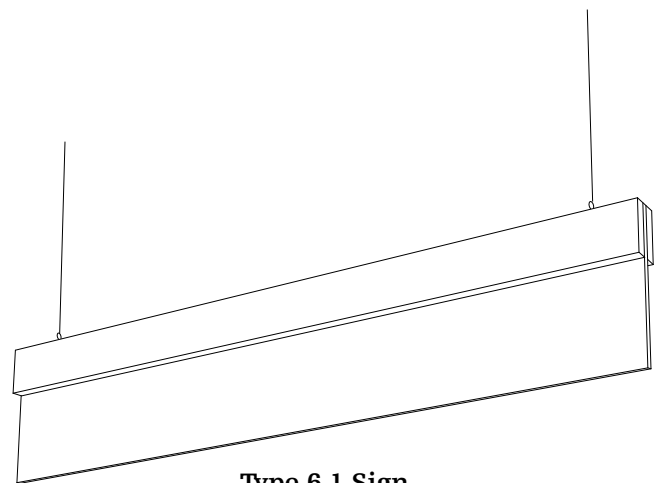

**Type 6.1 Sign**  
**– Perspective View**

## Hanging Directional Signs

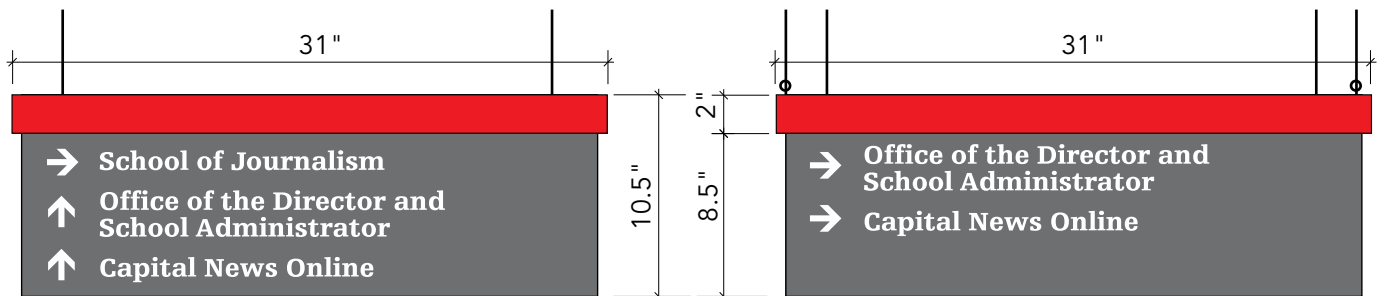
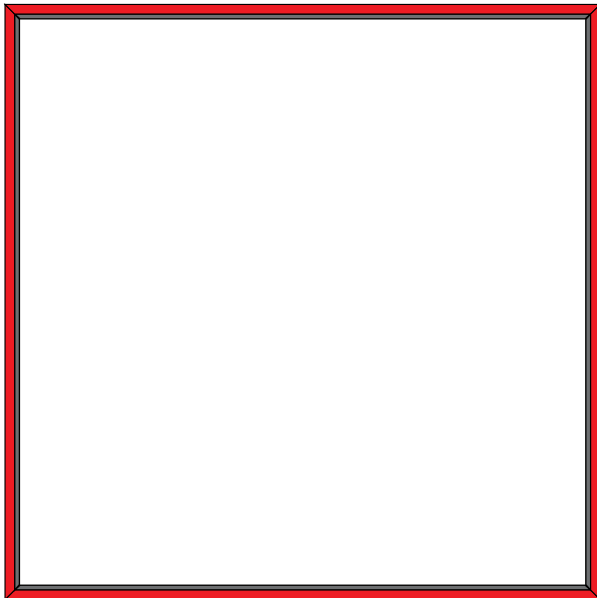

**Type 6sq Sign**  
**Double-sided Hanging Directional Sign**

**MATERIALS:**

- 1/4" gray 'sintra' (foamed PVC)
  - painted gray on both sides
  - white vinyl icon and text on both sides
- 1/2" acrylic - clear - painted red on visible surfaces

**INSTALLATION:**

- 1) Hang from ceiling with steel cable.
  - Acoustic tile ceiling - use approved metal clip-on connector for ceiling system
  - Concrete ceiling & Drywall ceiling - use appropriate anchor with threaded eyelet

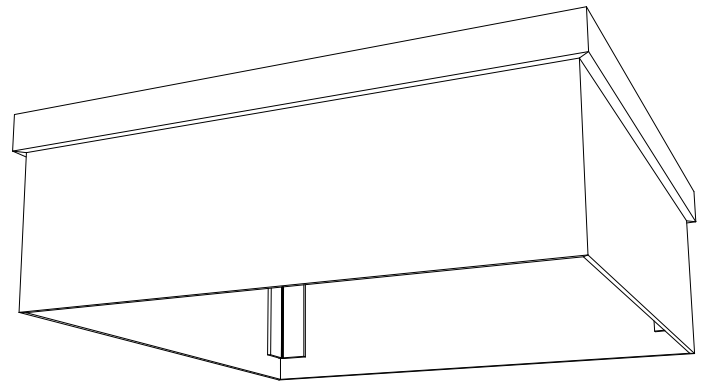

**Type 6sq Sign**  
**- Perspective View**

## Hanging Directional Signs

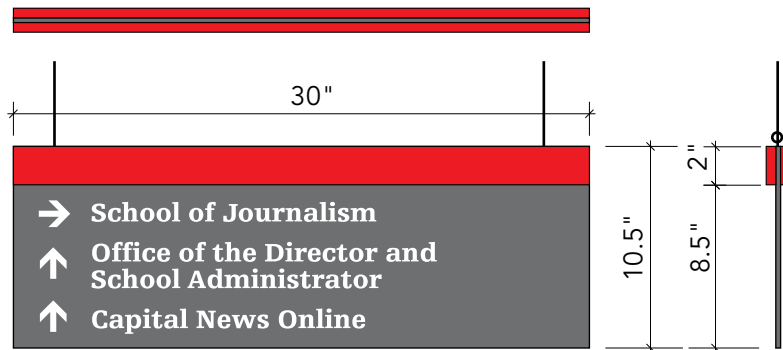

**Type 6.3 Sign**  
**Double-sided Hanging Directional Sign**

### **MATERIALS:**

- 1/4" gray 'sintra' (foamed PVC)
  - painted gray on both sides
  - white vinyl icon and text on both sides
- 1/2" acrylic – clear – painted red on visible surfaces

### **INSTALLATION:**

- 1) Hang from ceiling with steel cable.
  - Acoustic tile ceiling - use approved metal clip-on connector for ceiling system
  - Concrete ceiling & Drywall ceiling - use appropriate anchor with threaded eyelet

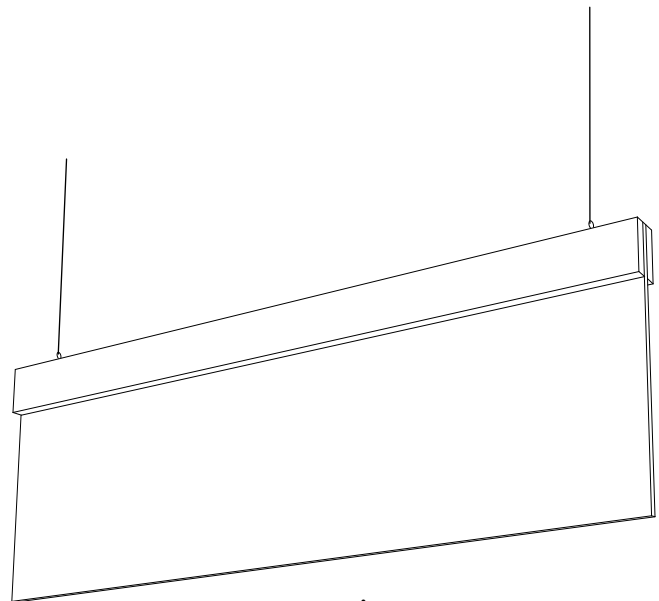

**Type 6.3 Sign**  
**- Perspective View**

## Small Hanging Directional Signs

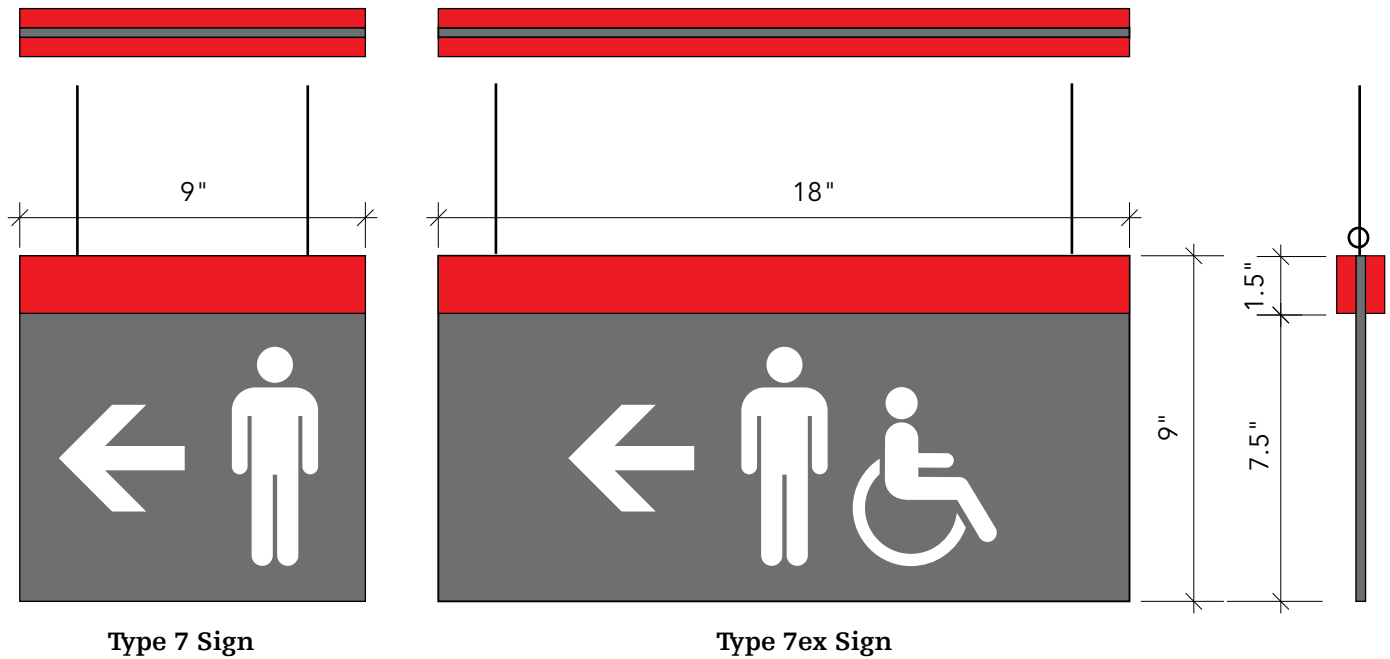

### MATERIALS:

- 1/4" gray 'sintra' (foamed PVC)
  - painted gray on both sides
  - white vinyl icon and text on both sides
- 1/2" acrylic – clear – painted red on visible surfaces

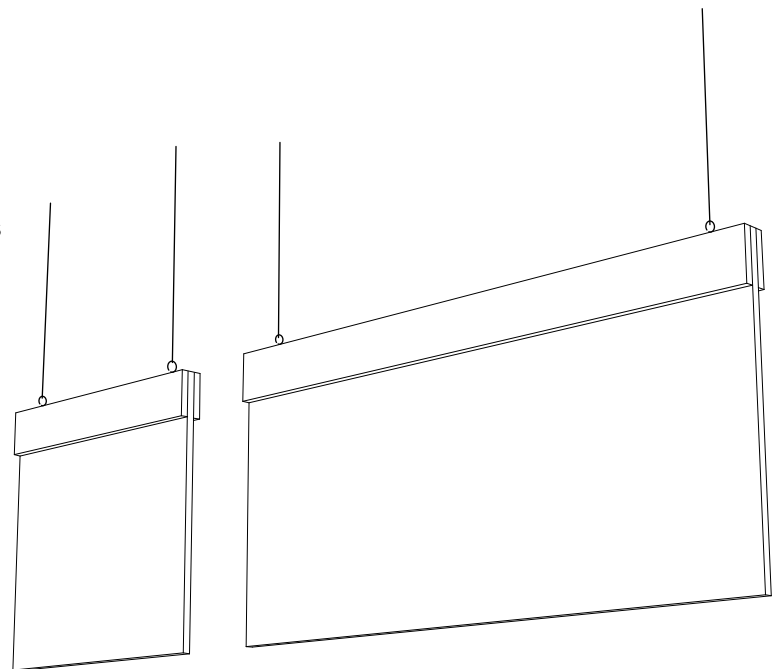

**Type 7 & 7ex Signs  
– Perspective View**

### INSTALLATION:

- 1) Hang from ceiling with steel cable.
  - Acoustic tile ceiling - use approved metal clip-on connector for ceiling system
  - Concrete ceiling & Drywall ceiling - use appropriate anchor with threaded eyelet

## Department & Wall Directional Signs

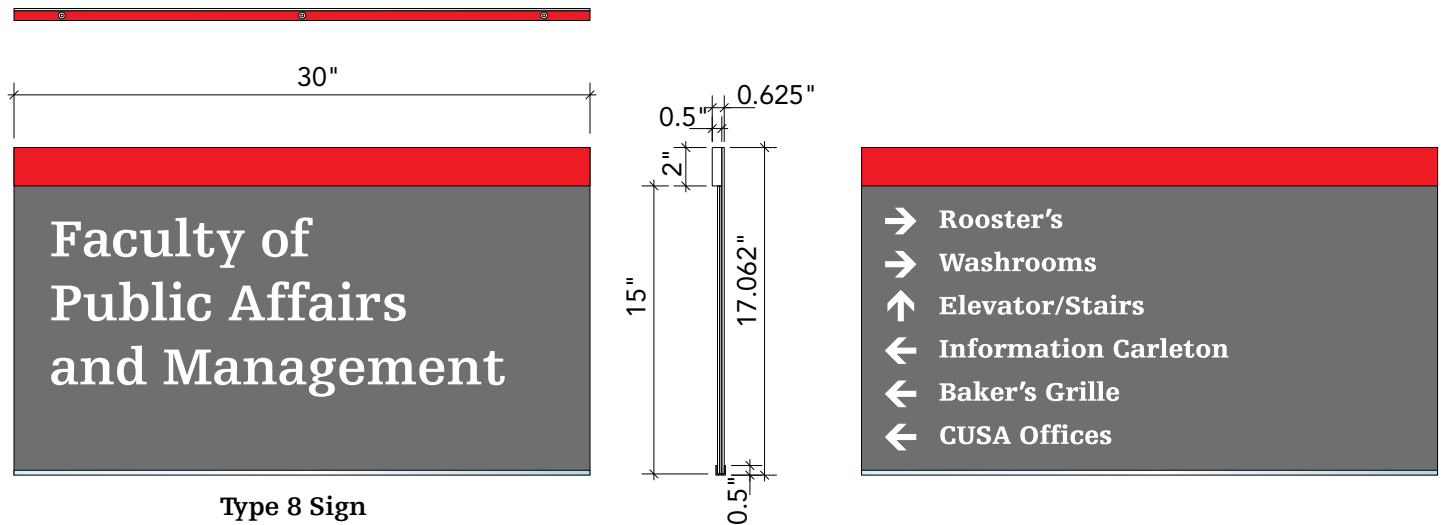

### MATERIALS:

- 1/8 gauge aluminum
- 1/2" x 1/2" aluminum channel - clear anodized
- 1/8" acrylic - clear - painted dark gray on back
- 1/8" acrylic - P99 (anti-glare frosting) with white vinyl on back
- 1/2" acrylic - clear - painted red on visible surfaces

### DISASSEMBLY for TEXT PANEL CHANGE:

- Remove 3 - #6 x 1" countersunk machine screws on top to remove red bar; allows 1/8" acrylic panels to be removed

### INSTALLATION:

- 1) Install with 4 to 6 - #8 countersunk screws into wall (with anchors - as required)
  - ensure screw heads are set back into depressions far enough to not scratch paint on back of gray graphic panel
- 2) Slide gray graphic panel into place - painted surface faces wall
- 3) Slide P99 (with vinyl text) panel into place - vinyl faces wall
- 4) Place red bar over panels & onto tabs. Insert #6 screws & thread into hole. DO NOT OVER TIGHTEN

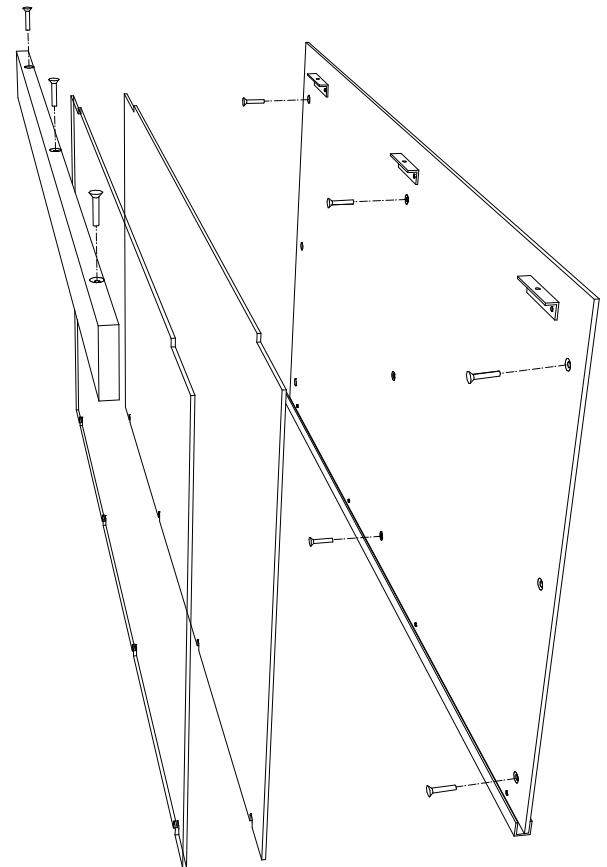

**Type 8 Sign**  
- Exploded Perspective View

# Type 9

## Faculty Directory Signs

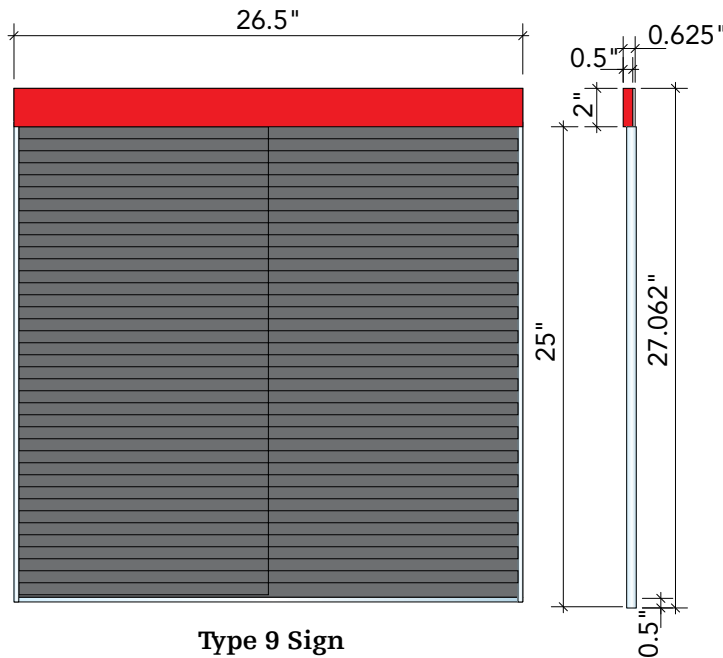

Type 9 Sign

### MATERIALS:

- 12 gauge steel painted silver
- 1/2" x 1/2" aluminum 'C' channel - clear anodized
- 1/2" x 1/2" aluminum angle - clear anodized
- 3/32" acrylic blades – clear – painted dark gray on back with white vinyl on front
- 1/8" acrylic – P99 (anti-glare frosting)
- 1/2" acrylic – clear – painted red on visible surfaces

### DISASSEMBLY for TEXT PANEL CHANGE:

- Remove 3 - #6 x 1" countersunk machine screws on top to remove red bar; allows 1/8" acrylic panel to be removed for access to blades

### INSTALLATION:

- 1) Install with 4 to 6 - #8 countersunk screws into wall (with anchors - as required)
  - ensure screw heads are set back into depressions far enough to not scratch paint on back of gray graphic panel
- 2) Apply blades to steel panel with magnetic tape - painted surface faces wall
- 3) Slide P99 panel into place - frosted side forward
- 4) Place red bar over panels & onto tabs. Insert #6 screws & thread into hole. DO NOT OVER TIGHTEN

## Wall Blade Signs

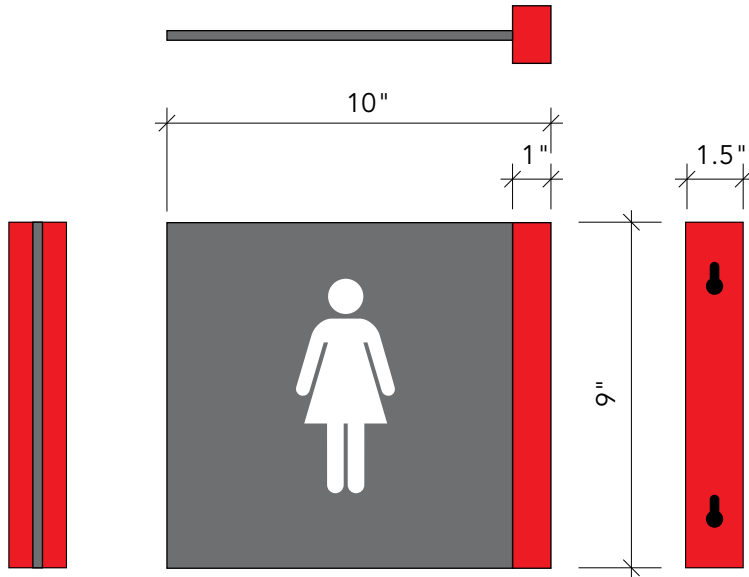

**Type 10 Sign**

---

### **MATERIALS:**

- 1/4" gray 'sintra' (foamed PVC)
    - painted gray on both sides
    - white vinyl icon and text on both sides
  - 1" x 1.5" MDF bar - painted red
- 

---

### **INSTALLATION:**

- 1) Install screws in wall (6.5" apart) - leave enough thread out to hold keyholes securely
- 2) Install sign onto screws (with keyholes) AND silicon adhesive on back.

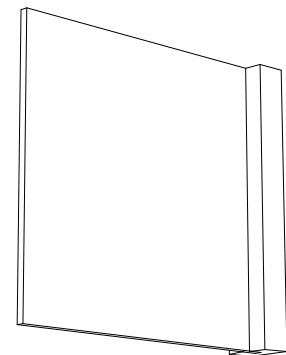

**Type 10 Sign**  
- Perspective View

# Type 11 & 11lg Notice Holders

## A.3.11

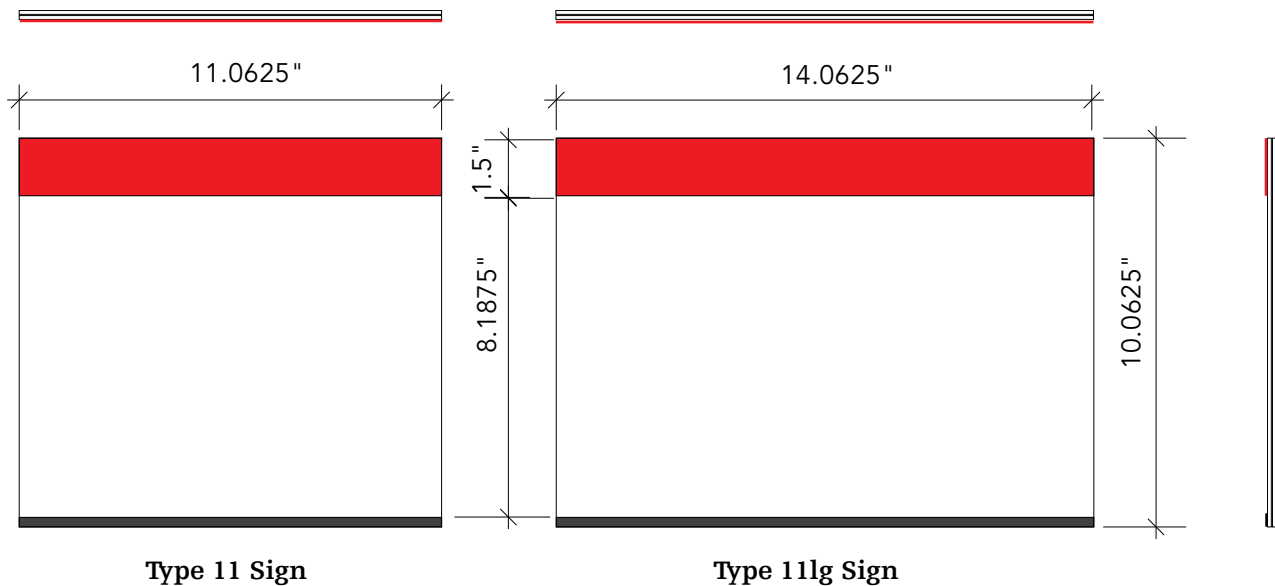

### MATERIALS:

- 1/8" black acrylic
- 1/16" acrylic – P99 (anti-glare frosting)
- backscreened 0.020" 'velvet-smooth' lexan (red and black) trim strips on front

### INSERT CHANGE:

- Remove laser printed insert by inserting "post-it" note; press on front acrylic to adhere to insert and pull out (either) side
- Alternate method:
- Insert thick card stock in either side to push insert out
- Do not use hard materials (rulers etc) to avoid scratching sign.

### INSTALLATION:

- 1) Install with perimeter foamtape (set 1/4" back from edges) 3M #4032 x 1/2" width.
- 2) Follow manufacturer's directions for surface preparation and application.

8.5" x 11" paper insert

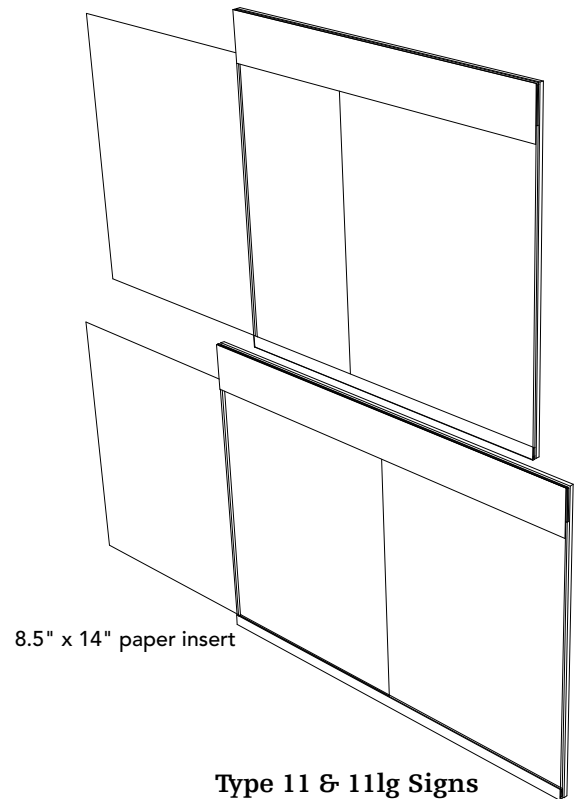

Type 11 & 11lg Signs  
– Perspective Views



# Type 1 & 1pb

## Room Signs

0.5" Egyptianne F 65 Bold - 72pt - right justified **132** 0.425" 1.1" 1.1" 0.5" 0.75" **Unicentre Store** **Staff Only** Egyptianne F 65 Bold - 55pt on 66pt leading Maximum 3 lines of text dashed line show limit of text **Typical Room** 229B Storage Most typical room use

0.75" **2132A** Egyptianne F 65 Bold - 55pt on 66pt leading **Pool Office** **Staff Only** Avenir 85 Heavy - 42pt on 50pt leading **Typical Room with subtext**

0.665" **2101A** Egyptianne F 65 Bold - 50pt on 60pt leading **Diane Dodds** **Fitness Testing Lab** Avenir 85 Heavy - 36pt on 43pt leading **Typical Office**

# Type 2 & 2pb

## Large Room Signs

# A.4.2

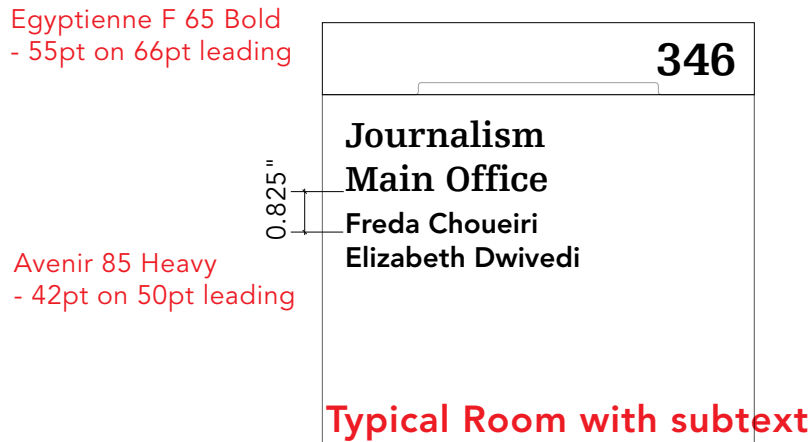
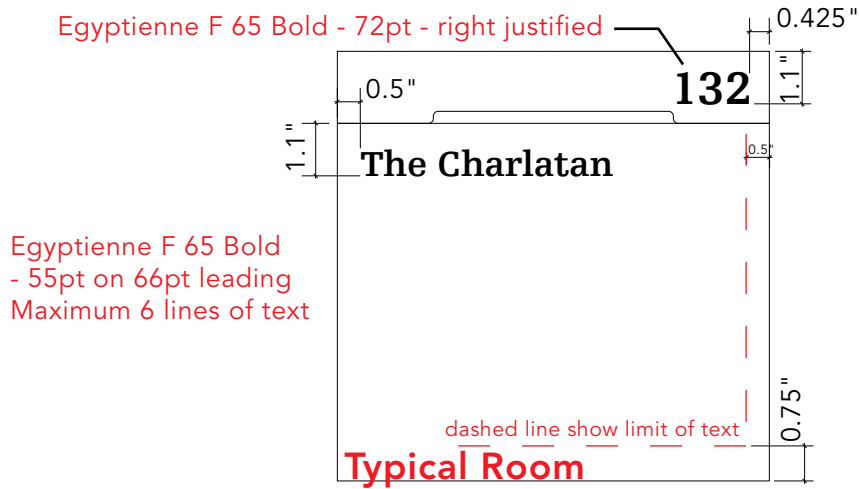

## Notice Signs – Typical Icons 1

Egyptienne F 65 Bold  
- 72pt - right justified

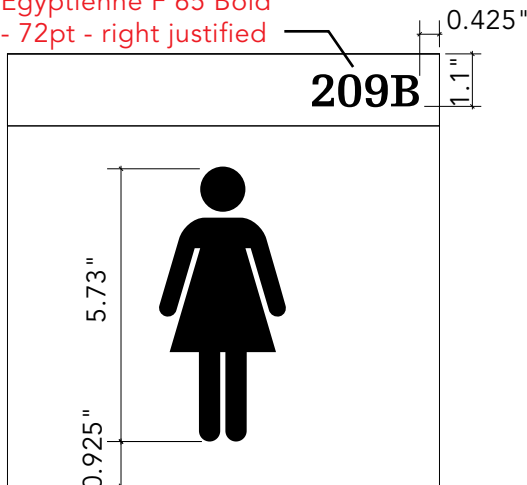

3fw

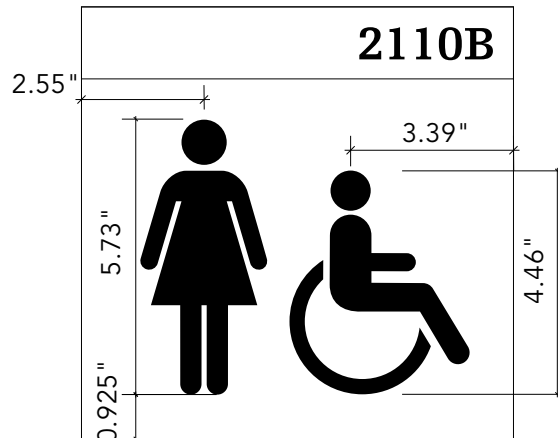

3fh

all icons shown on this page are ISO symbols

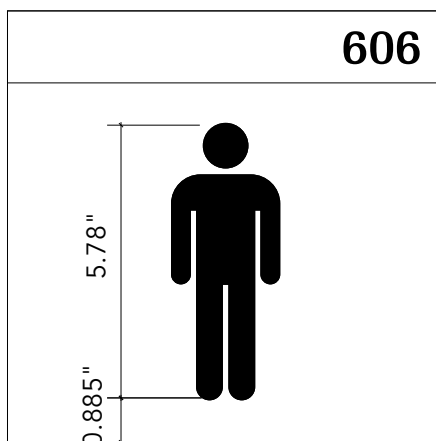

3mw

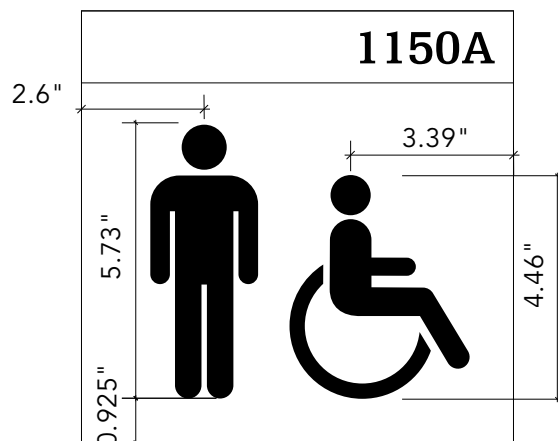

3mh

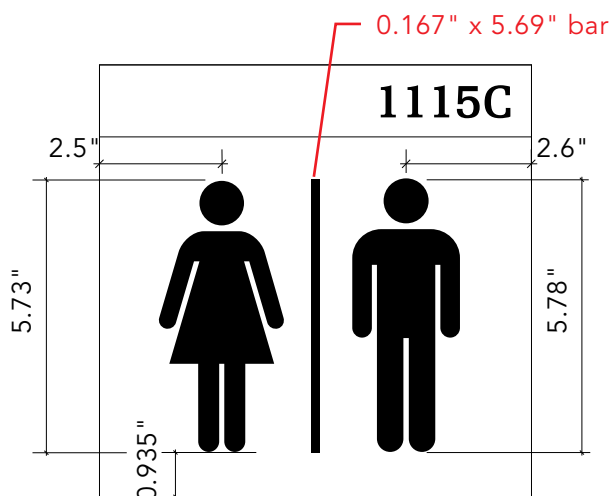

3uw

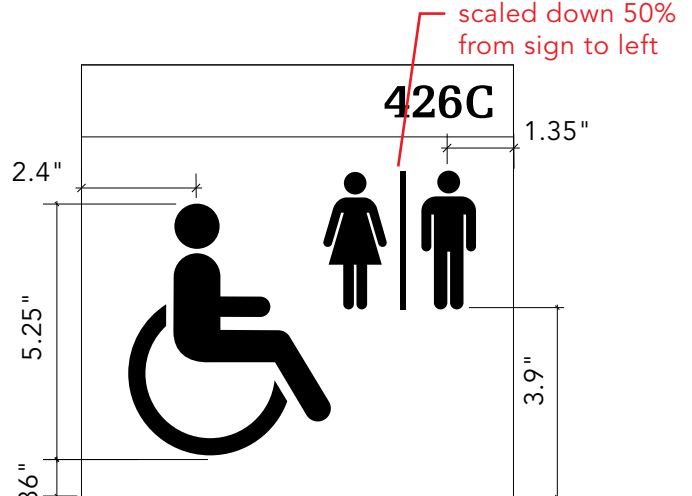

3uh

## Notice Signs – Typical Icons 2

Egyptienne F 65 Bold  
- 72pt - right justified

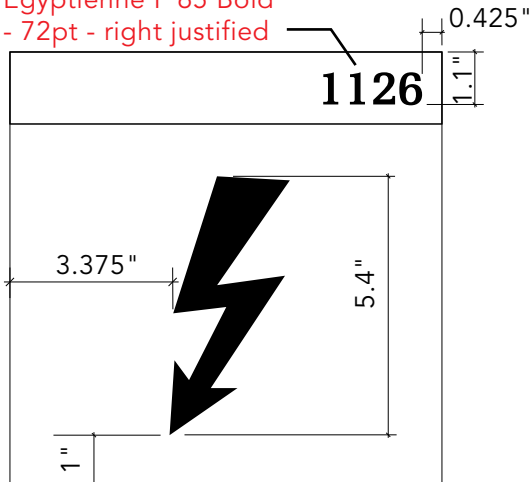

3el

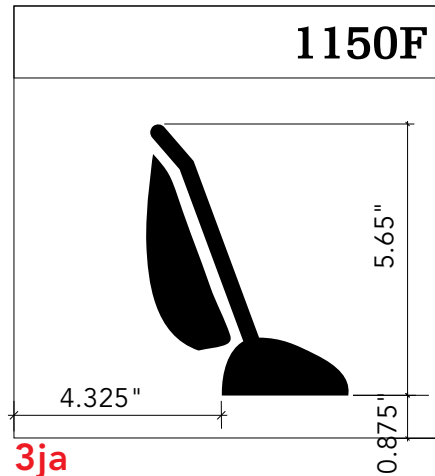

3ja

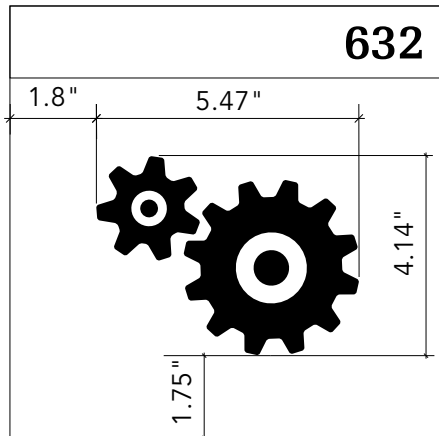

3me

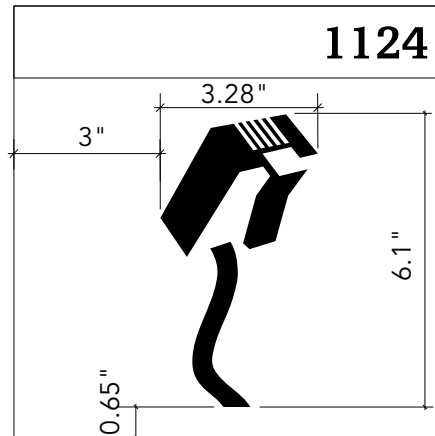

3it

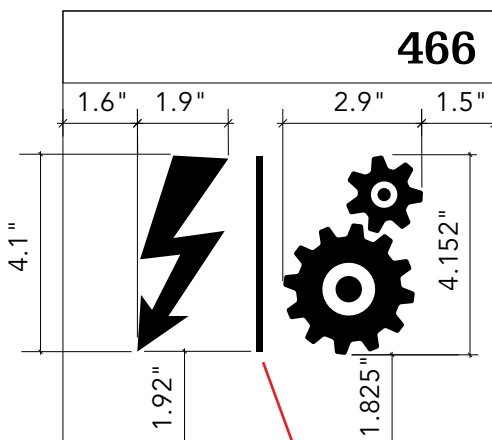

3em

0.14" x 4" bar

Icons are not ISO - Available from Carleton upon request

Notice Signs – Special Icons

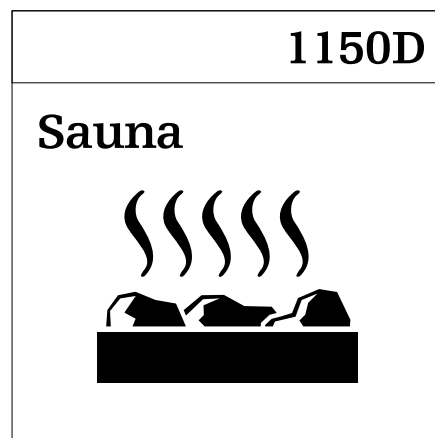
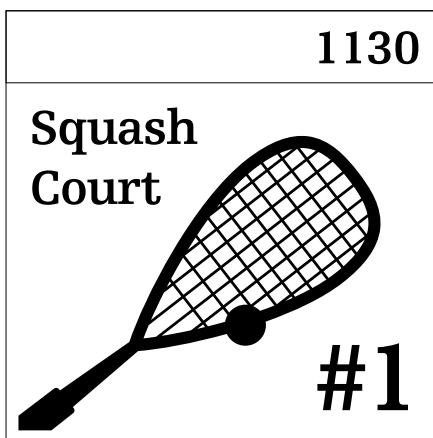
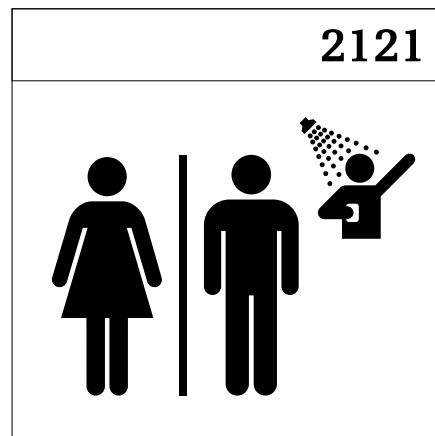
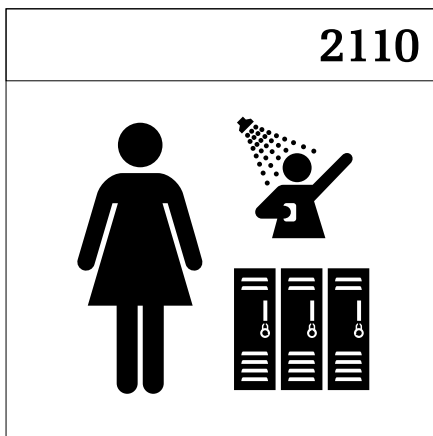
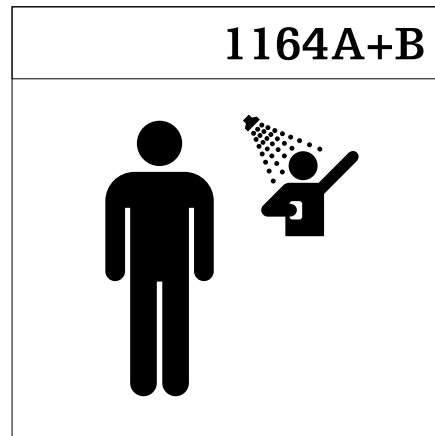
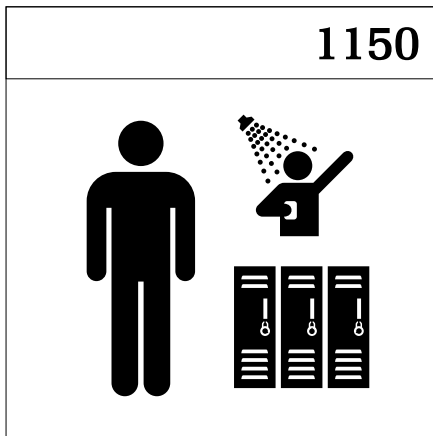

These are examples of custom icons created for special applications – when modifying/creating custom icons: aim for clear, uncluttered, panels with generous breathing space

## Notice Signs – Text Notices (Typical)

<p><b>3n1</b></p> <p>No Access Emergency Exit Only</p>	<p><b>3n2</b></p> <p>0.5" 1.455" 1.9"</p> <p>Emergency Exit Only Alarm Will Sound</p> <p>Egyptienne F 65 Bold - 90pt on 108pt leading</p>	<p><b>3n3</b></p> <p>Exterior Exit Only</p>
<p><b>3n4</b></p> <p>No Access</p>	<p><b>3n5</b></p> <p>Egyptienne F 65 Bold - 80pt on 96pt leading</p> <p>Please use other stairwell for access to</p> <p>1.25"</p> <p>XXXXXXXXXXXXXXXXXXXX XXXXXXXXXXXXXXXXXXXX XXXXXXXX XXXXXXX Egyptienne F 65 Bold - 48pt on 58pt leading</p>	<p><b>3n6</b></p> <p>Roof Access</p>
<p><b>3n7</b></p> <p>Exit</p>	<p><b>3n8</b></p> <p>To Stairs</p>	

## Tactile Stair Signs

Avenir 85 Heavy  
- 315pt - centre justified

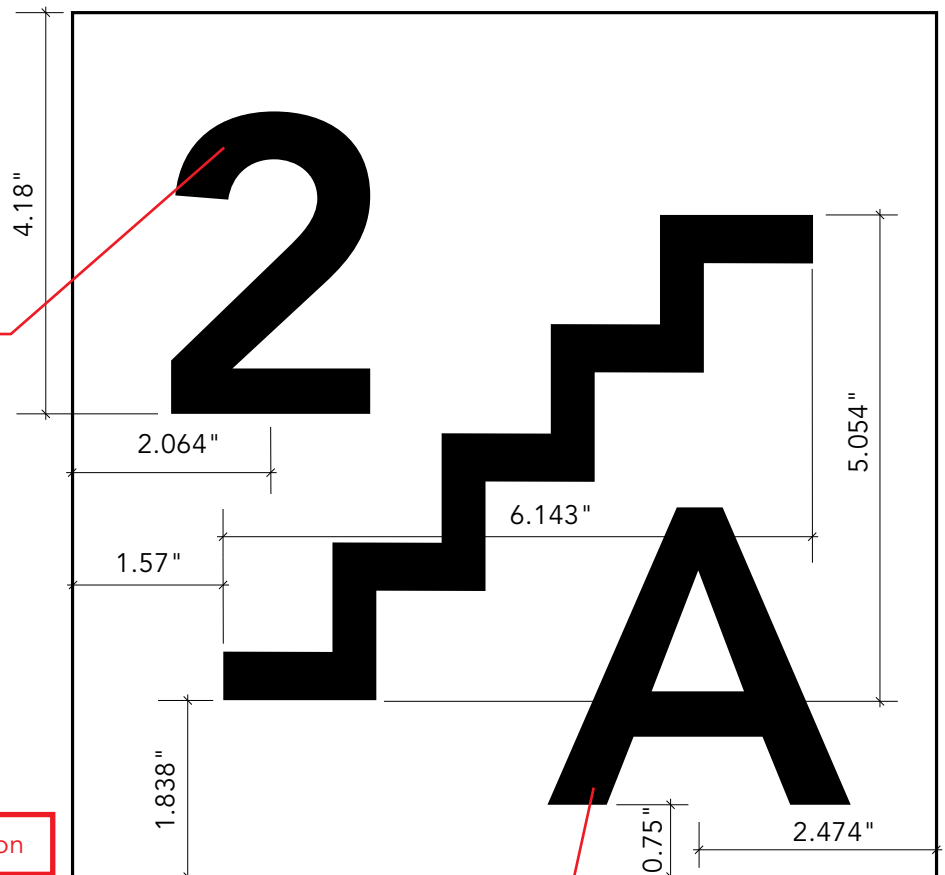

Steps are ISO icon

Avenir 85 Heavy  
- 315pt - centre justified

8.5" outer diameter  
7.5" inner diameter

Avenir 85 Heavy  
- 315pt - centre justified  
centred in sign

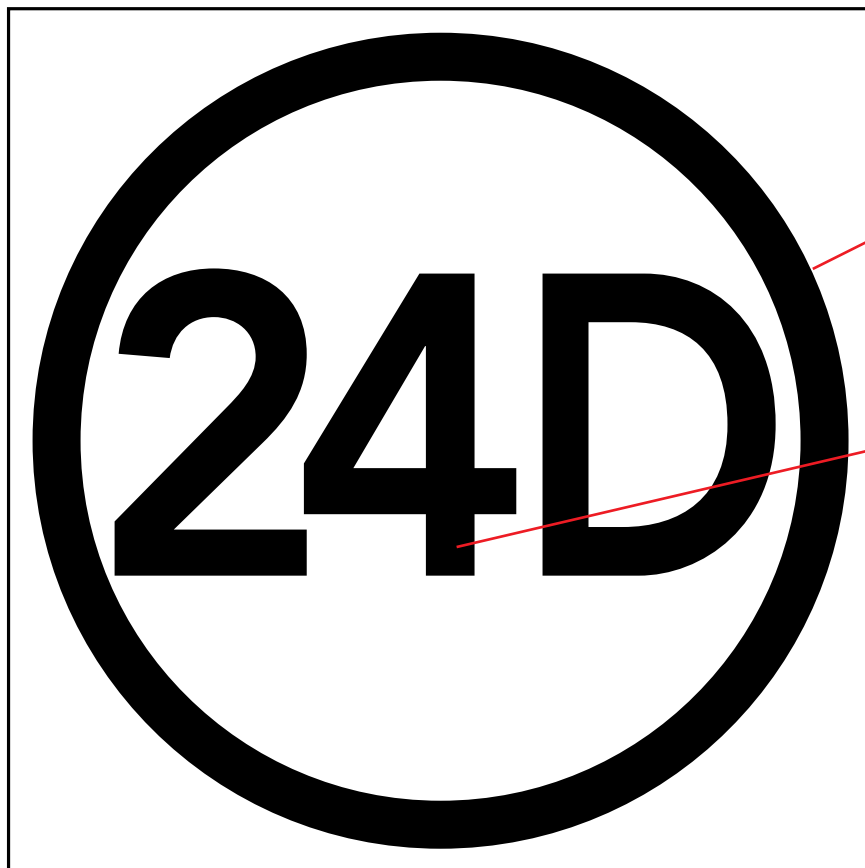

## Large Room & Directory Signs

**1115**

**The Sports Therapy Clinic**  
 Physiotherapy, Massage Therapy, Acupuncture

**520-3511**  
 www.thesportstherapyclinic.com

**Hours: Mon–Thurs 7am–6pm, Fri 7am–3pm**

Dimensions: 1.35" (top left), 0.668" (top right), 1.525" (right), 2" (left), 1.1" (left), 2.1" (left), 2.375" (left), 1" (left)

Font Specifications:

- Egyptienne F 75 Black - 100pt on 120pt
- Avenir 95 Black - 55pt on 75pt
- Avenir 95 Black - 50pt on 70pt
- Avenir 95 Black - 55pt on 75pt
- Avenir 95 Black - 60pt on 72pt

Right side font: Egyptienne F 75 Black - 100pt on 120pt - right justified

**Other Variants:**  
 please note there is more variability & flexibility for this sign type than others. Final layout must respect appearance, font use & layout already established

**1110B**

**Customer Service  
 Membership &  
 Registration**

**Hours: Mon–Fri 8:30am–4:30pm**

**Instructional Media Services**

→ **D283 Media Technology Distribution**  
 Equipment Pickup/Return  
 Reservations

**Level 3**

Dimensions: 10.8" (width), 0.406" (height), 2" (left), 1.875" (left), 0.935" (left), 1.583" (right)

Font Specifications:

- Avenir 95 Black - 30pt - right justified
- Avenir 55 Roman - 63pt - right justified
- Egyptienne F 75 Black - 36pt on 50pt
- Egyptienne F 75 Black - 75pt for 'Level' - 130pt for # - right justified

LEVEL 1  
 Athletic Therapy Centre  
 Control Centre  
 Customer Service, Membership & Registration  
 Fieldhouse  
 Men's Locker Room, Pool  
 Ravens' Nest  
 Sports Medicine Clinic  
 Sports Therapy Clinic  
 Squash Courts  
 Visiting Team Rooms

LEVEL 2  
 Administration  
 Alternate Needs Change Room  
 Cardio Room  
 Classroom  
 Fitness Centre  
 Fitness Studio  
 Squash Gallery  
 Women's Locker Room, Pool

LEVEL 3  
 Pool Gallery

**Other Variants:**  
 please note there is more variability & flexibility for this sign type than others. Final layout must respect appearance, font use & layout already established

**Level 3**

LEVEL 1  
 Art Gallery  
 Reader's Digest Resource Centre  
 Lecture Theatre  
 Washrooms

LEVEL 2  
 Art Gallery

LEVEL 3  
 Canada NewsWire Newsroom  
 Centretown News  
 CU Survey Centre  
 Journalism Main Office  
 Office of the Director  
 Office of the School Administrator  
 Radio News  
 Wilfrid Eggleston Room

LEVEL 4  
 Art History Graduate Students  
 Audio-Visual Resource Centre  
 Film Studios Graduate Students  
 Harold A. Morrison Room  
 School of Studies in Arts and Culture Secretariat  
 Student Lounge

**Level 3**

LEVEL 1  
 Oliver's Vending  
 Tim Horton's

LEVEL 2  
 Food Court  
 Mike's Place  
 Muslim Prayer Room  
 Porter Hall  
 Ziggy's

LEVEL 3  
 ACCESS TO LEVELS 1 AND 2  
 Restricted Access

LEVEL 4  
 No Access



## Hanging Directional Signs

4"  
1.25"  
0.9"  
2.25" 2.1875"

**↓ Level 2 - Ziggy's**  
**↓ Level 2 - Porter Hall**  
**↓ Level 2 - Food Court**  
**↓ Level 2 - Mike's Place**  
**↓ Level 1 - Classrooms**

Egyptienne F 75 Black  
- 100pt on 162pt leading  
- maximum 6 lines

**↑ School of Studies of Art & Culture**  
**↑ Classrooms 412, 415, 417, 435 & 436**  
**↑ Men's Washroom Barrier-Free**

1.5"  
2.1875"

**Resource Centre**

Type 6.1 can be used without arrow for indicating areas etc.

1.64"  
1.64"

Full Size ISO Arrow for reference

## Small Hanging Directional Signs

Type 7 are dimensionally similar to Type 3 – please refer to A.4.3 for the dimensions and placement for these signs

All icons shown on this page are ISO symbols

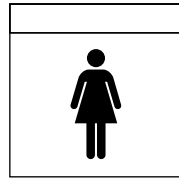

7fw



7fh

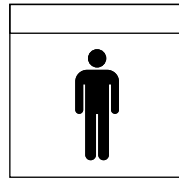

7mw



7mh



7uw



7uh

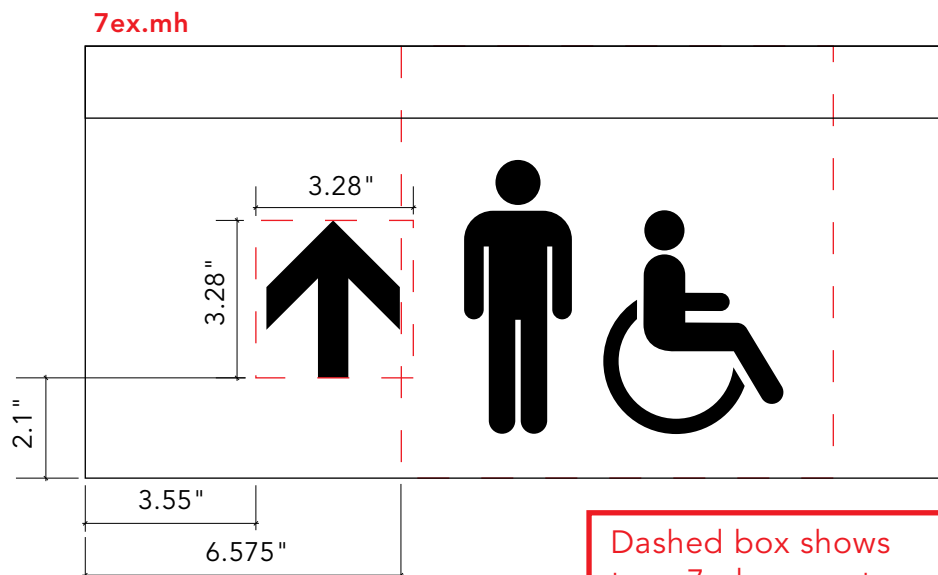

Dashed box shows type 7 placement within extended panel size - use Type 3 art guidelines

## Department & Wall Directional

4"

0.9"

1.25"

2.1875"

↓ **Level 2 - Ziggy's**

↓ **Level 2 - Porter Hall**

↓ **Level 2 - Food Court**

↓ **Level 2 - Mike's Place**

↓ **Level 1 - Classrooms**

Egyptienne F 75 Black  
- 100pt on 162pt leading  
- maximum 6 lines

Type 8 is dimensionally similar to Type 6 and can be laid out using same dimensions

1.865"

3.668"

**Faculty of  
Public Affairs  
and Management**

Egyptienne F 65 Bold  
- 200pt on 240pt leading  
- maximum 4 lines

## Faculty Directory Signs – Blade Art

---

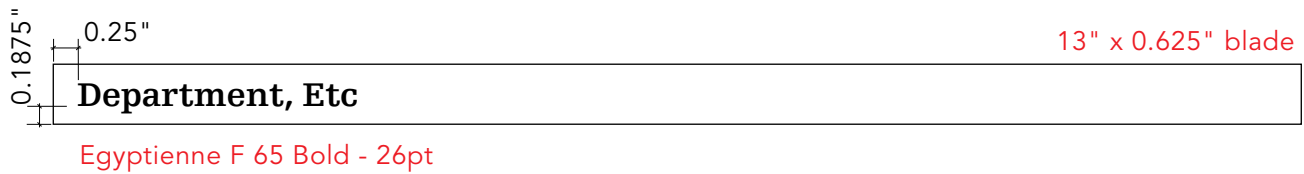

## Wall Blade Signs

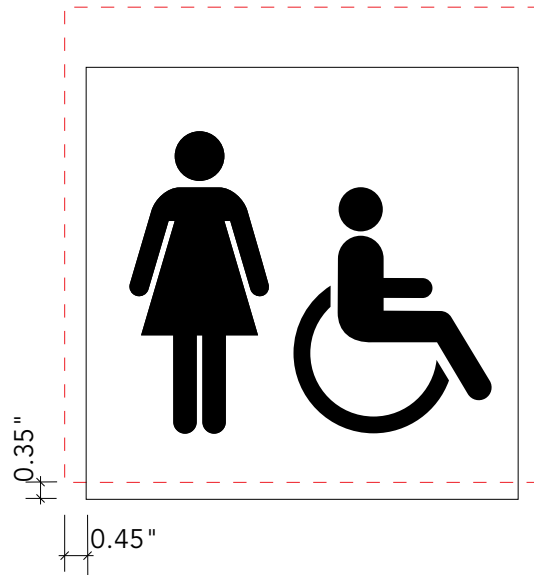

Dashed box shows  
type 3 enlarged  
110% and placed  
within type 10 panel  
- use type 3 art and  
enlarge 110% and  
place as shown

Notice Holders

Egyptienne F 65 Bold - 72pt on 86.5 leading

# Tape Return

Note: The Loeb Building doors are LOCKED at night. The building is accessible 24 hours by tunnel from the direction of Southam Hall.

Avenir 55 Roman - 42pt on 50.5pt leading



TYPICAL USE  
8.5" x 11"

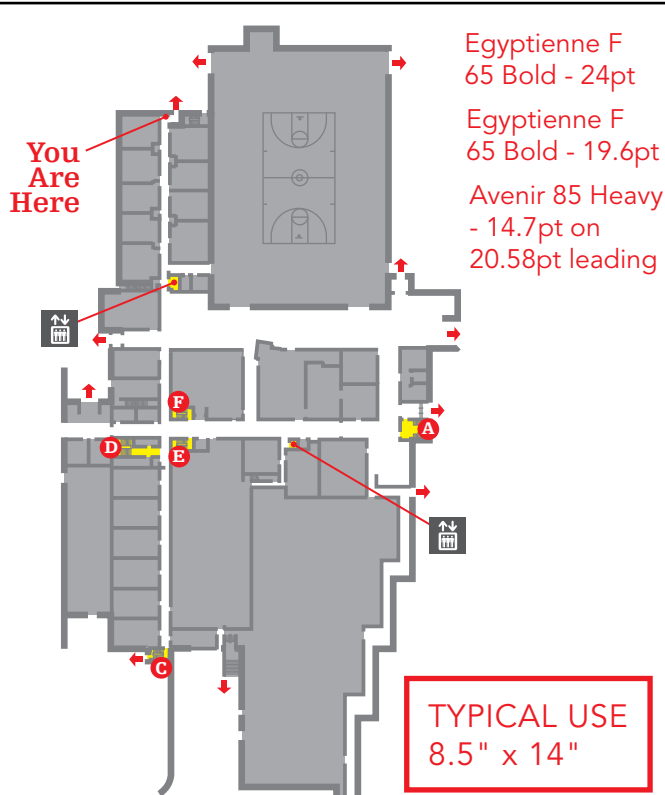

Egyptienne F 65 Bold - 24pt

Egyptienne F 65 Bold - 19.6pt

Avenir 85 Heavy - 14.7pt on 20.58pt leading

5" x 0.429" red bars

### In Case of Fire

#### If You Discover a Fire

- Leave the area of danger.
- Close all doors in the path of exit.
- Sound the fire alarm.
- Telephone Carleton University Emergency Number from an area of safety: 4444 or 520-4444 from any campus pay phone (no charge).
- Use a safe exit stairwell.

### Do Not Use Elevators

#### Upon Hearing Fire Alarm

- Turn off all equipment.
- Feel the door before opening it; if warm, remain in your area.
- If not, leave building via nearest exit, closing doors behind you.

#### Caution

- If smoke is heavy in the corridor, it may be safer to remain in your area; close and seal door opening.
- If you encounter smoke in the stairway, use alternate exit or, if all stairways are affected, it may be safer to remain in your area.

TYPICAL USE  
8.5" x 14"

### Remain Calm

# Type 1 & 1pb Room Signs

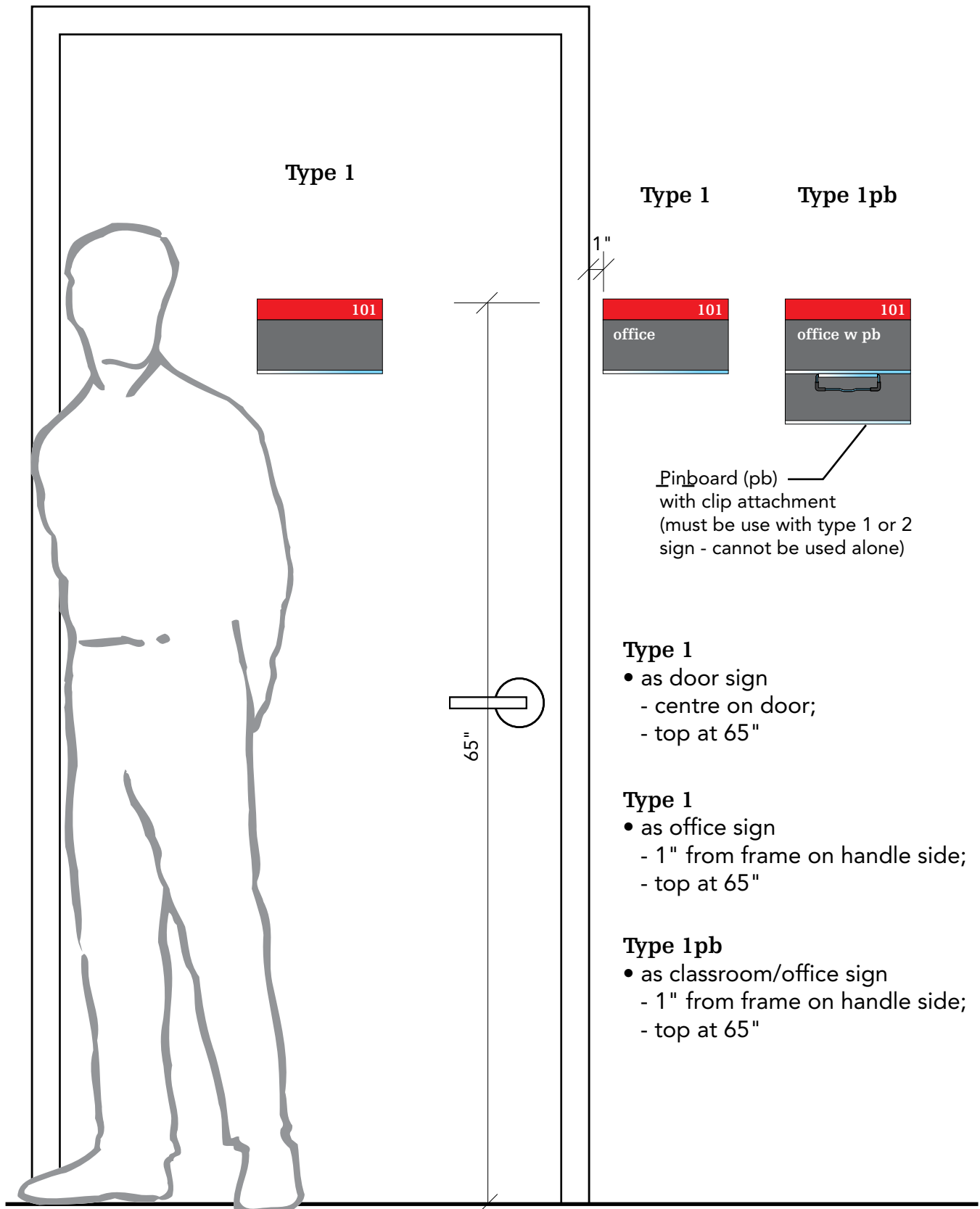

# Type 2 & 2pb

## Large Room Signs

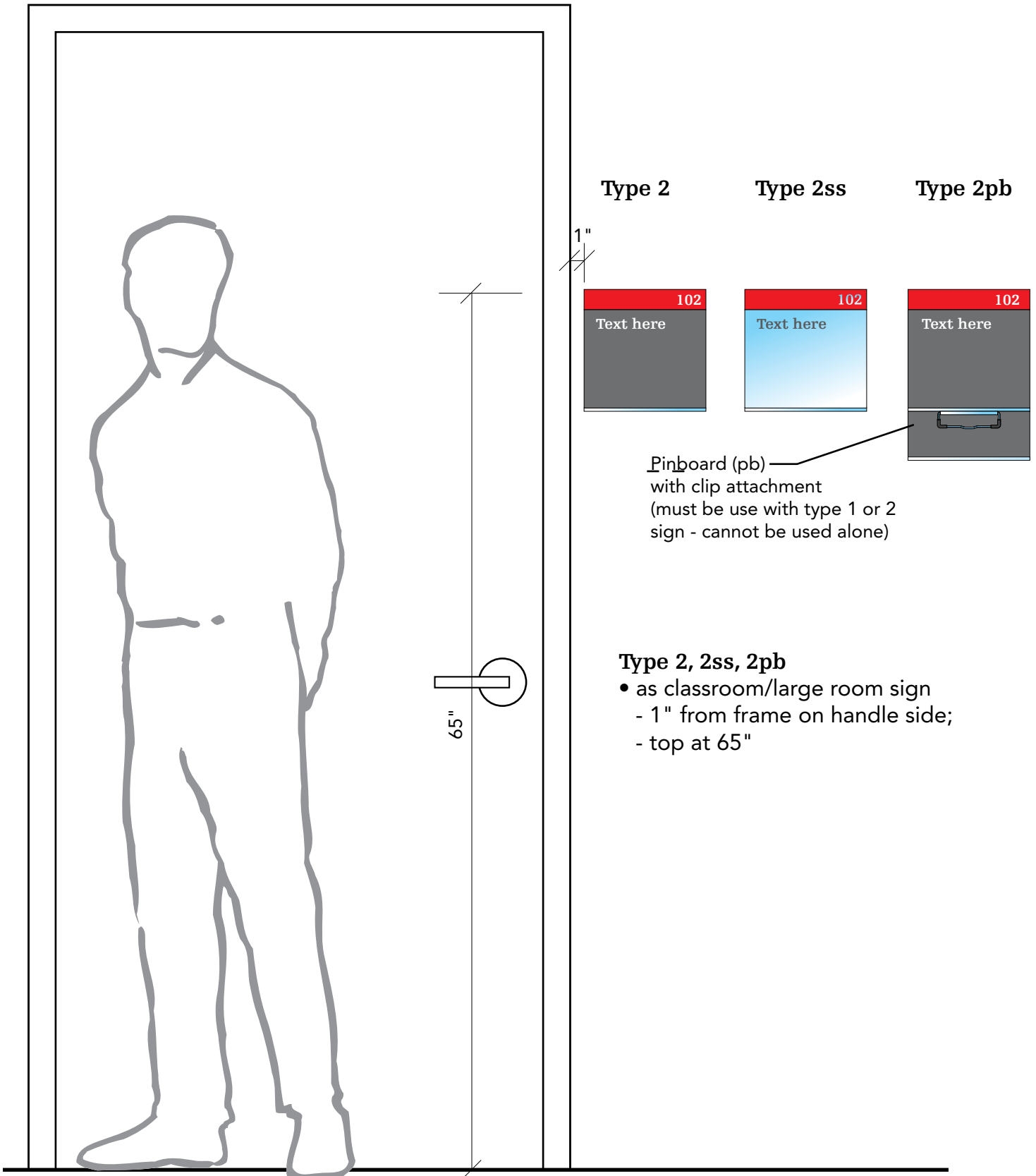



## Facilities Signs (All types)

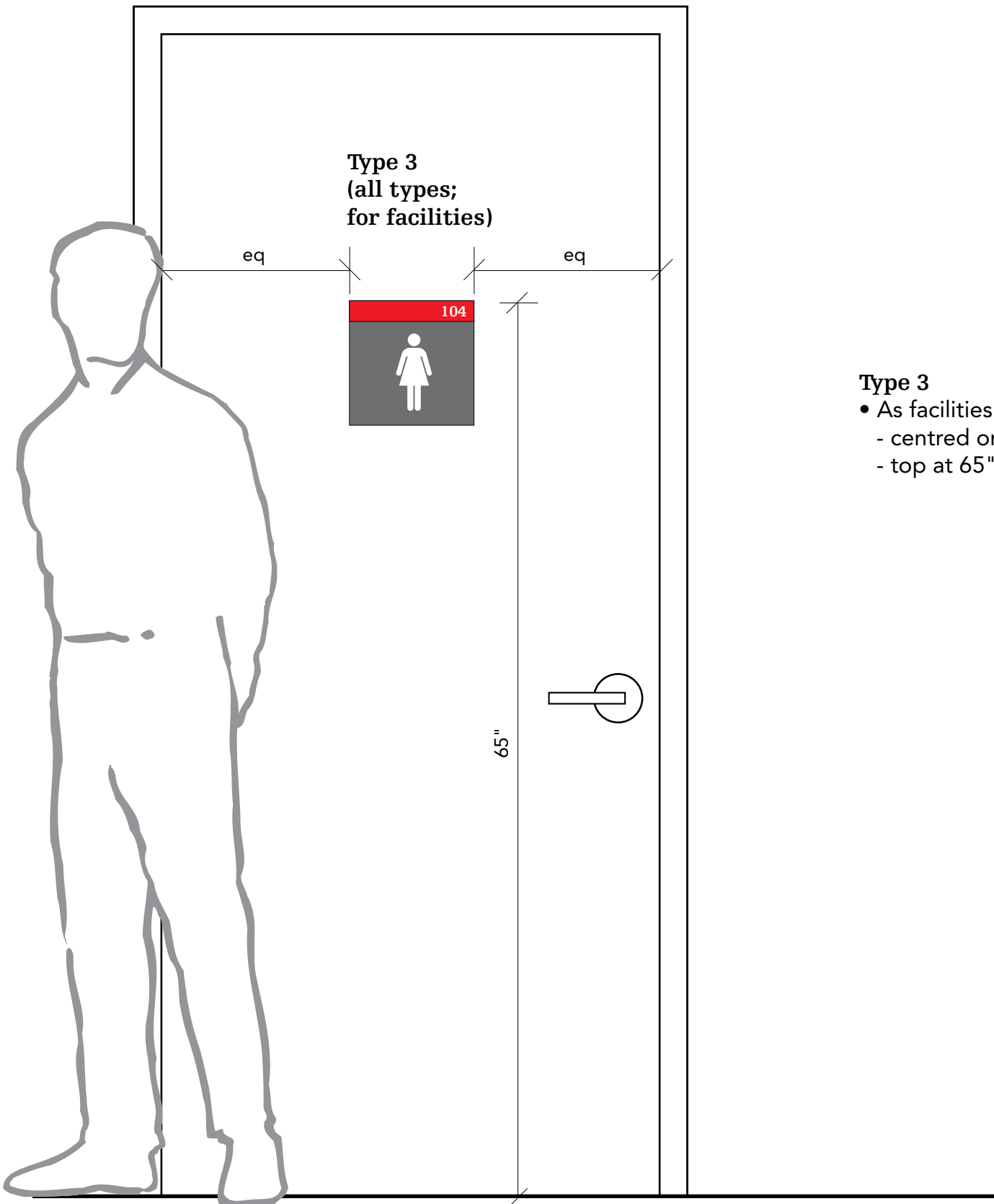

### Type 3

- As facilities & notice
  - centred on door;
  - top at 65"

# Type 4 Stair Signs

# A.5.4

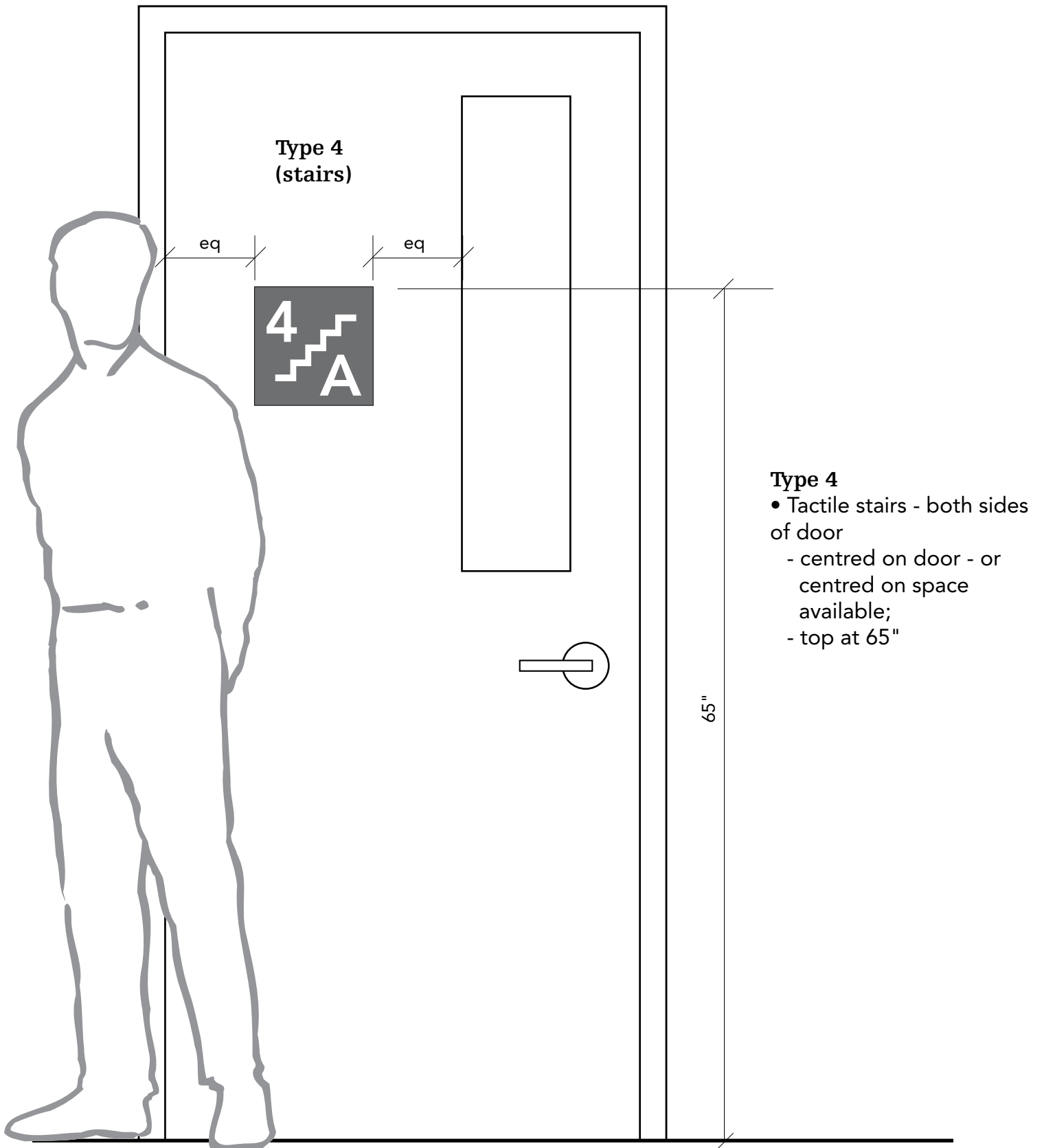

## Large Room & Dedication Signs

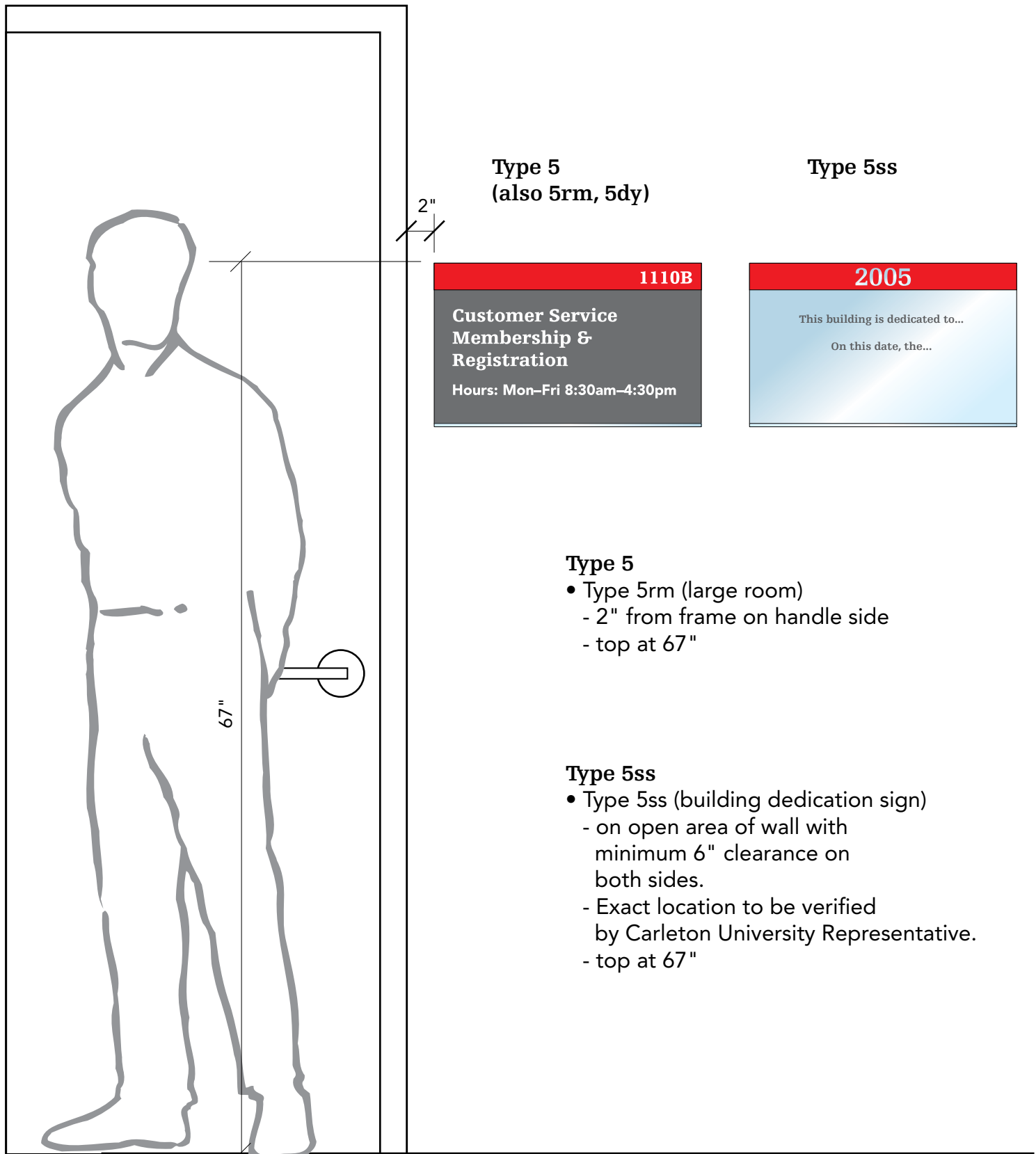

# Type 5dy & 5dy.fp

## Directory Signs

# A.5.5.1

### Type 5dy.fp

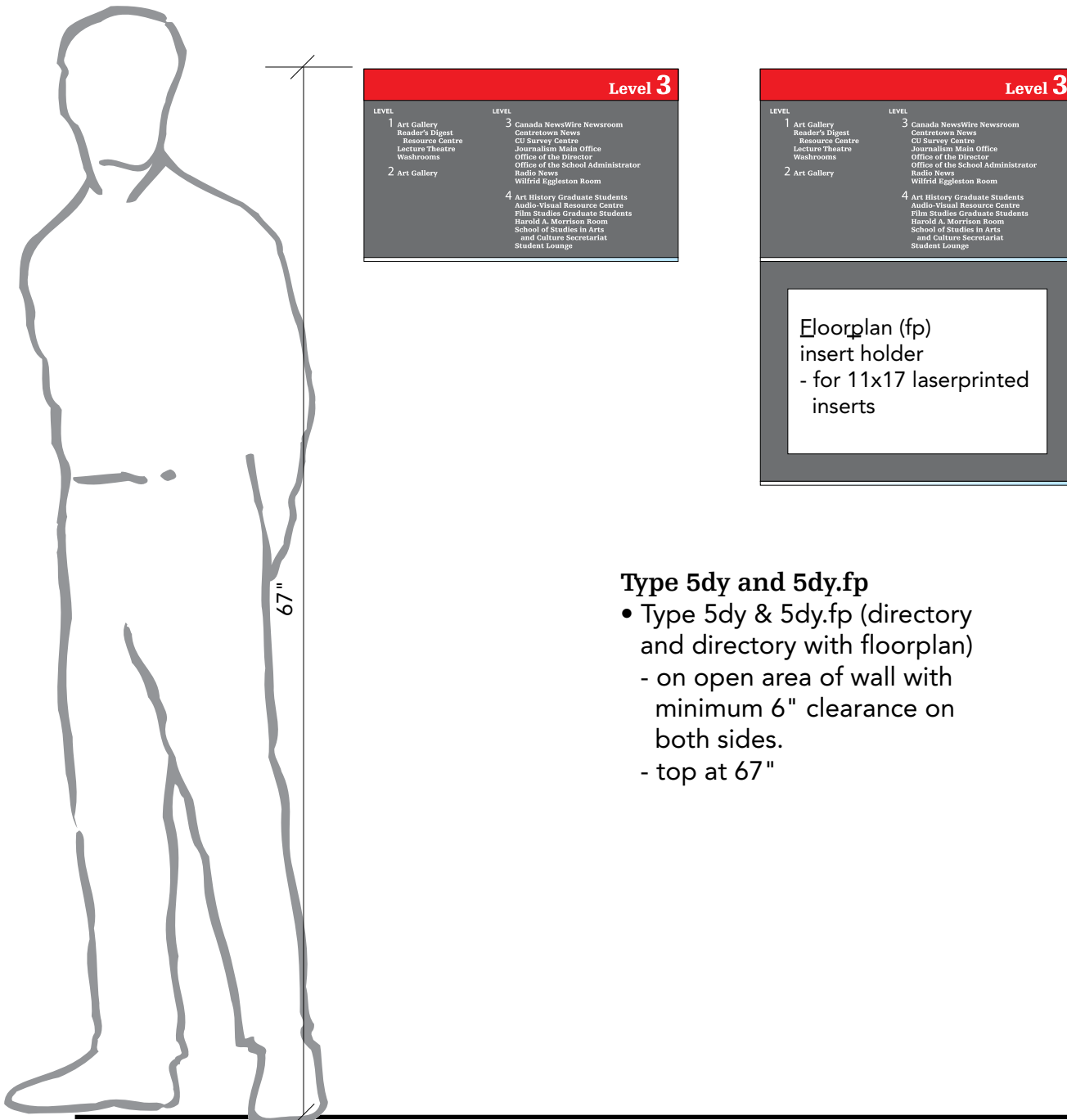

### Type 5dy and 5dy.fp

- Type 5dy & 5dy.fp (directory and directory with floorplan)
  - on open area of wall with minimum 6" clearance on both sides.
  - top at 67"

## Hanging Directional Signs



**Type 6**



**Type 6.1**

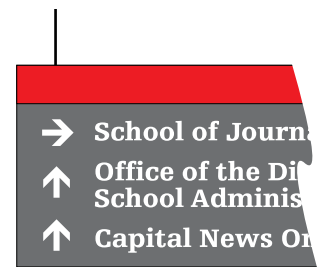

**Type 6sq**

**Type 6.3**

### Type 6, 6.1, 6.3, 6sq

- All Type 6 hanging directional signs to be hung - centred in hallway etc
- For 6, 6.3 & 6sq bottom cannot be lower than 96"
- For all - preferred top height is 113"
- For low ceiling situations Type 6.1 can be hung with top 1" from ceiling - bottom cannot be lower than 90" in this case

\*96"

\*to bottom - lowest possible installation height

113"

minimum preferred top height

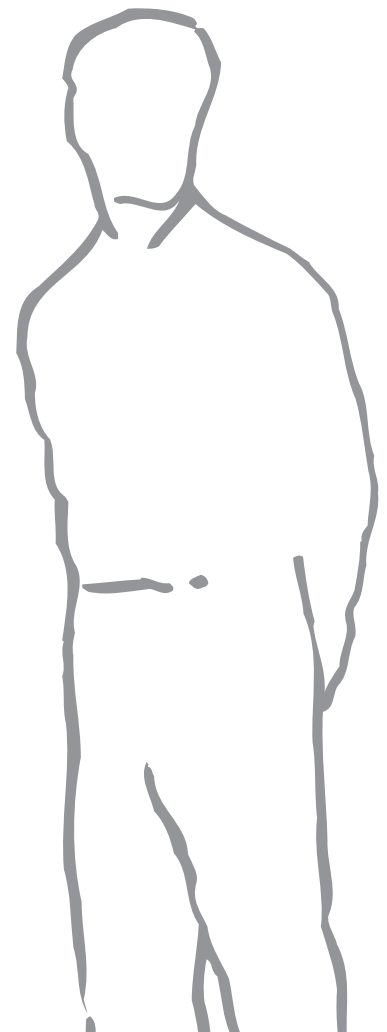

## Small Hanging Directional Signs

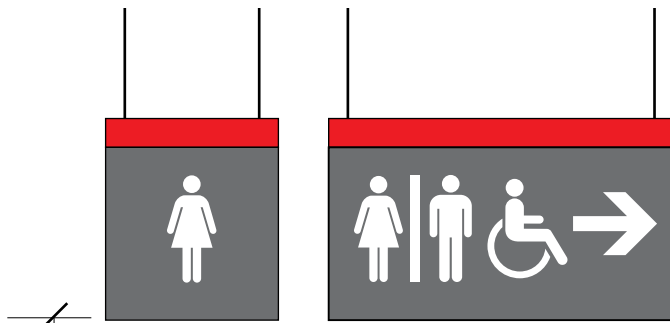

Type 7

Type 7ex

\*96"  
\*to bottom - lowest possible installation height

### Type 7 & 7ex

- All Type 7 hanging directional signs to be hung - centred in hallway etc
- Bottom cannot be lower than 96" in freehanging installations
- Can be hung with top 1" from ceiling - bottom cannot be lower than 90" in this case

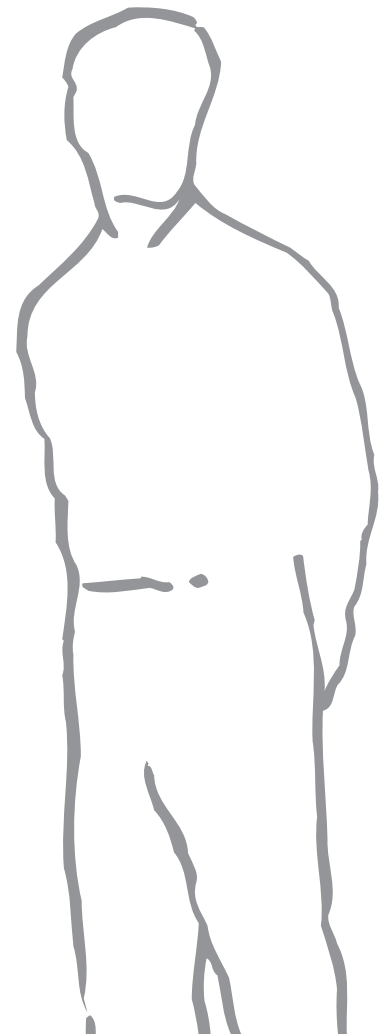

## Department & Wall Directional Signs

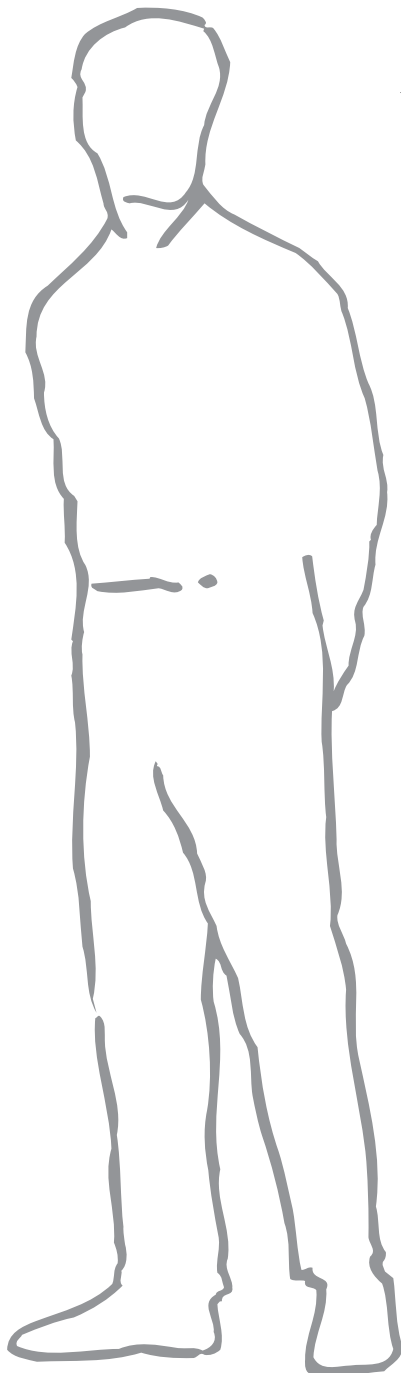

**Type 8**  
(also 8dl, 8rm)



### **Type 8**

- Type 8rm & 8dl (large room & wall-mounted directional)
  - top at 67"
  - must have 6" clearance all around to any obstruction including doors, walls, corners, pillars, fire alarm pulls, pipes, etc.

# Type 9

## Faculty Directory Signs

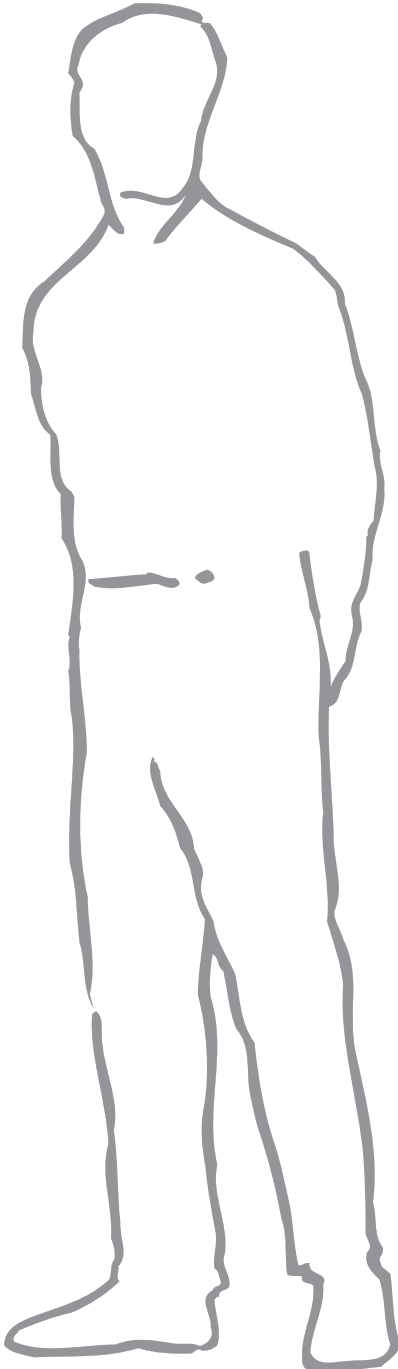

Text here in vinyl	
artwork supplied	
Text here in vinyl	
artwork supplied	
Text here in vinyl	
artwork supplied	
Text here in vinyl	
artwork supplied	
Text here in vinyl	
artwork supplied	
Text here in vinyl	
artwork supplied	
Text here in vinyl	
artwork supplied	
Text here in vinyl	
artwork supplied	
Text here in vinyl	
artwork supplied	
Text here in vinyl	
artwork supplied	
Text here in vinyl	
artwork supplied	
Text here in vinyl	
artwork supplied	

Sign Type 9

### Type 9

- Type 9 (faculty directory)
  - top at 77"
  - must have 6" clearance all around to any obstruction including doors, walls, corners, pillars, fire alarm pulls, pipes, etc.

77"



# Type 10 Wall Blade Signs

# A.5.10

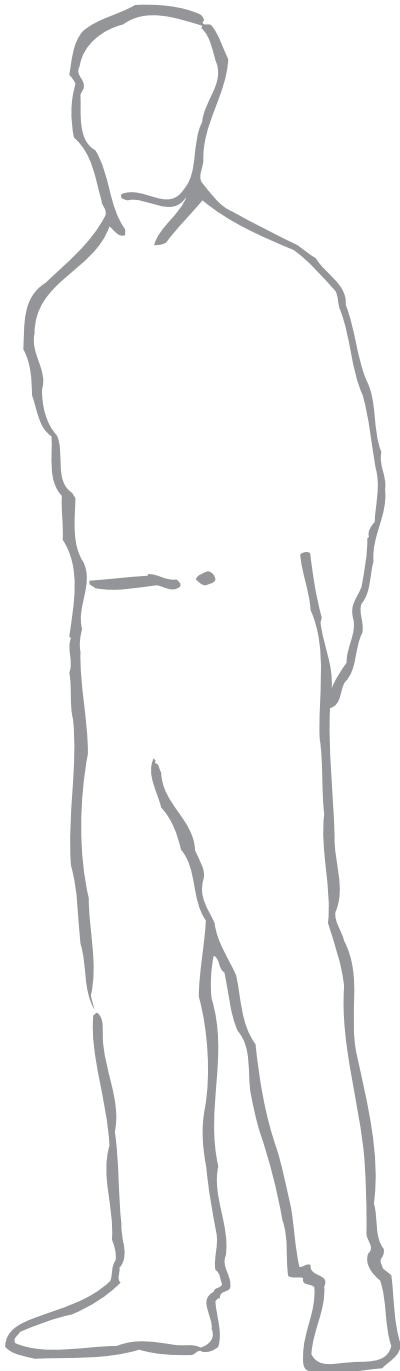

**Type 10**  
(10mw, 10 fw,  
10mh etc.)

96"  
\*to bottom - lowest  
possible installation height

### **Type 10**

- All Type 10 wall-mounted facility signs to be hung from wall near or above facility door/entrance
- Bottom cannot be lower than 96"

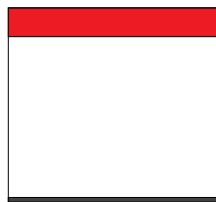
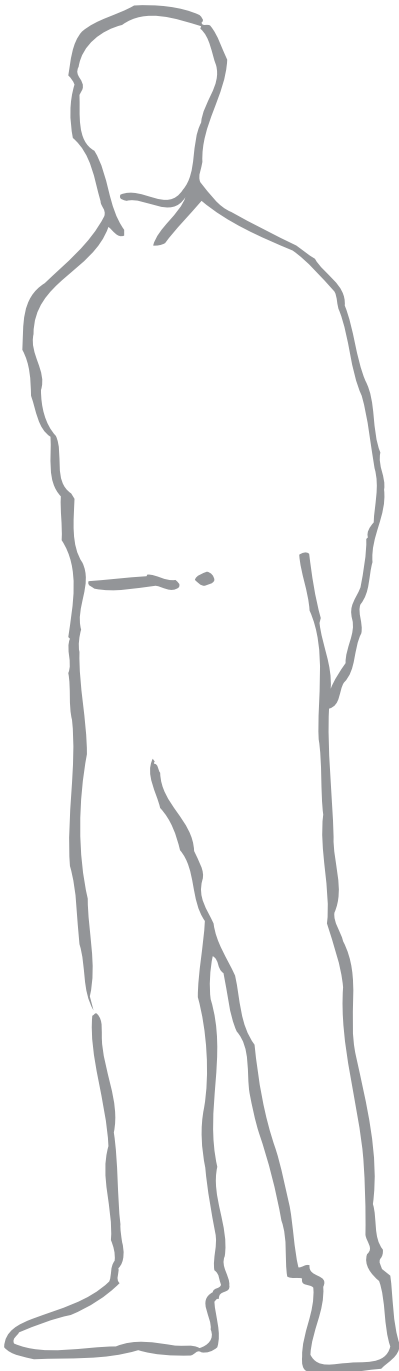

Type 11



Type 11lg

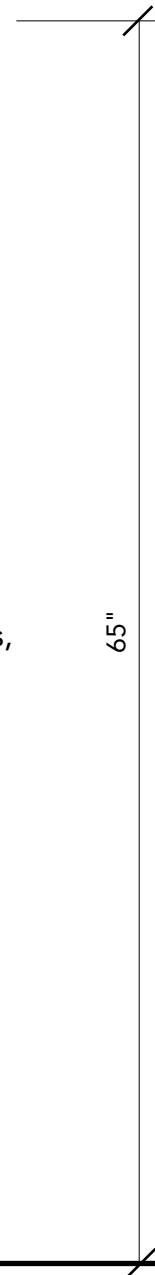

65"

### Type 11 & 11lg

- All Type 11 notice insert holders to be mounted to wall (taped)
  - top at 65"
  - must have 4" clearance all around to any obstruction including doors, walls, corners, pillars, fire alarm pulls, pipes, etc.

## **Cleaning**

- All interior signs should be cleaned periodically – especially those in dusty environments.
- Cleaning for all signs should be done with a damp soft rag and mild, non-abrasive soap. Do not use paper towels as they will leave more particles behind and could scratch the sign surface.
- All signs with vinyl text should be wiped gently as vinyl text can be damaged/removed by excessive rubbing.

## **Removal of Paint due to Vandalism**

- Some painted vandalism may be removed with solvents. The acrylics with textured surfaces will withstand small amounts of 'rubber cement' thinner and P95 can resist stronger solvents such as acetone.
- Always test solvents prior to use on any surface as most solvents will damage sign surfaces or inks.

## **For Types 1, 2, 5 & 8**

- If the surface is severely damaged, a replacement panel can be ordered and replaced by the user with a screwdriver.
- These signs were designed for easy panel replacement.

## **All Other Signs**

- The other signs (typically hanging) are not intended to resist vandalism and the subsequent cleaning.
- These signs must be replaced if cleaning is not effective or results in the vinyl text being removed.