

Section D Other Items

D.1.1 Other Items – Introduction

D.2 Typical Signs & Usage

- D.2.1** Bulletin Boards – 4', 6', 8'
- D.2.2** Locking Bulletin Boards – 4', 6'
- D.2.3** Display Showcases – 4', 6'
- D.2.4** Faculty 3D Wall Lettering
- D.2.5** Enhanced Overhead Signs
- D.2.6** Outdoor Sandwich Boards
- D.2.7** Wall Mounted Literature Rack
- D.2.8** Free Standing Poster Holder

D.3 Assembly Details

- D.3.1** Bulletin Boards – 4', 6', 8'
- D.3.2** Locking Bulletin Boards – 4', 6'
- D.3.3** Display Showcases – 4', 6'
- D.3.4** Faculty 3D Wall Lettering
- D.3.5** Enhanced Overhead Signs
- D.3.6** Outdoor Sandwich Boards
- D.3.7** Wall Mounted Literature Rack
- D.3.8** Free Standing Poster Holder

D.4 Sign Graphics

- D.4.1** Bulletin Boards, Locking Bulletin Boards & Showcases
- D.4.2** Faculty 3D Wall Lettering
- D.4.3** Enhanced Overhead Signs
- D.4.8** Free Standing Poster Holder

D.5 Installation

- D.5.1** Bulletin Boards – 4', 6', 8'
- D.5.2** Locking Bulletin Boards – 4', 6'
- D.5.3** Display Showcases – 4', 6'
- D.5.4** Faculty 3D Wall Lettering
- D.5.5** Enhanced Overhead Signs
- D.5.7** Wall Mounted Literature Rack

D.6 Maintenance

- D.6.1** Other Items – Maintenance

General Notes on Other Items

This section covers items which do not fit one of the previous categories, it will grow in the future as specialty items are added.

There are currently (Spring 2005) 6 types in this section:

- a) Bulletin Boards in 3 sizes (4', 6' & 8') - available in 4 colour combinations to match Faculty colours and Carleton Red.
- b) Locking Bulletin Boards in 2 sizes (4' & 6') - available in 4 colour combinations to match Faculty colours and Carleton Red.
- c) Display Showcases in 2 sizes (4' & 6') - available in 4 colour combinations to match Faculty colours and Carleton Red.
- d) Faculty 3D Wall Lettering for Departmental Reception Areas.
- e) Enhanced Overhead Door Signs for special applications, eg large dedicated rooms, gyms, etc.
- f) Sandwich Boards for temporary exterior announcements.

Section D.2 (Usage)

This section will aid in the appropriate selection of the sign(s) for the desired purpose.

Section D.3 (Details)

This section provides general information on the manufacture and installation of the sign(s). This is to be supplemented by the some production drawings for bulletin boards and enhanced overhead door signs, included in the appendices of this package.

Section D.4 (Graphics)

This section gives the font usage, size and location guidelines for laying out text and icons for the various signs.

Section D.5 (Installation Heights and Locations)

This section is to be used in conjunction with section A.3 to actually install the signs. Signs should only be installed by qualified (signage) technicians/painters.

Section D.6 (Maintenance)

This section provides recommendations for cleaning and dealing with vandalism.

Bulletin Boards – 4', 6', 8'

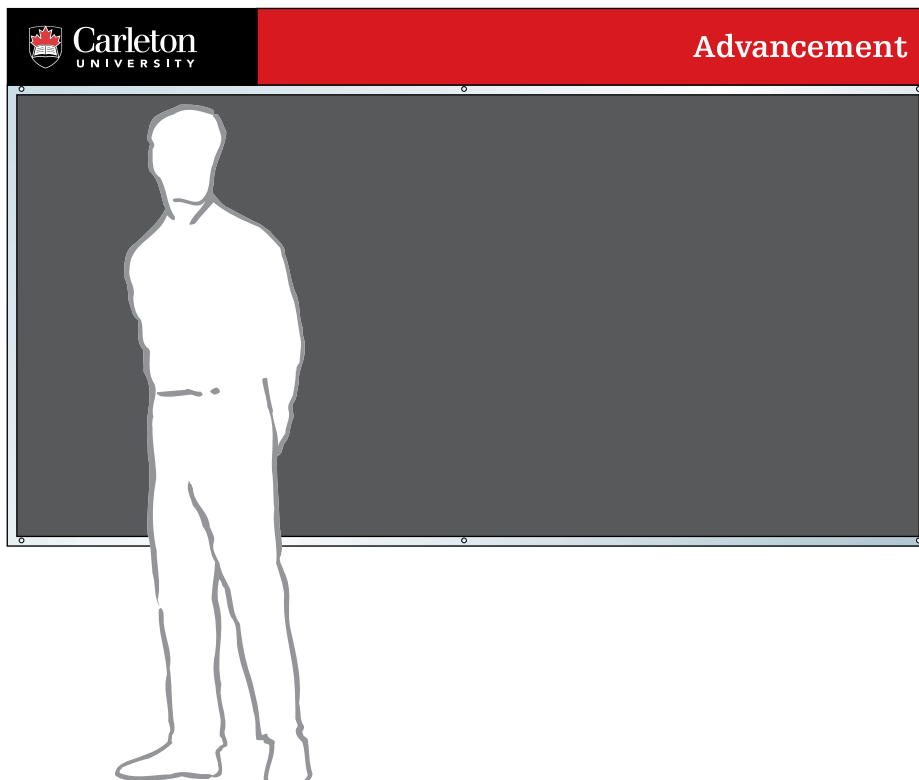
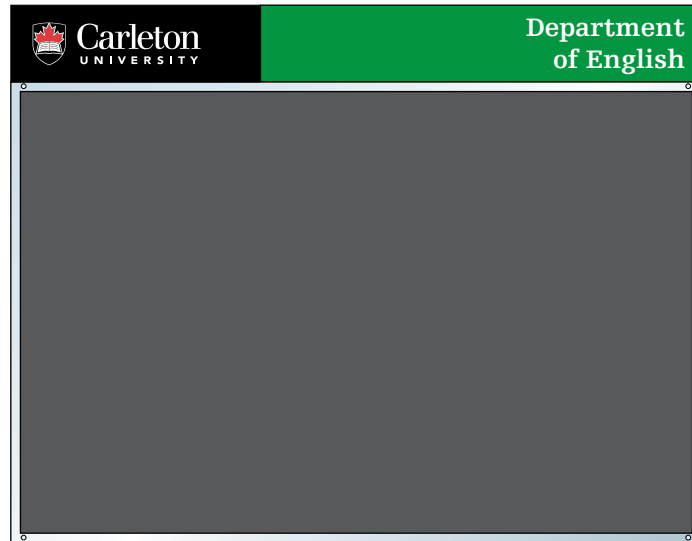
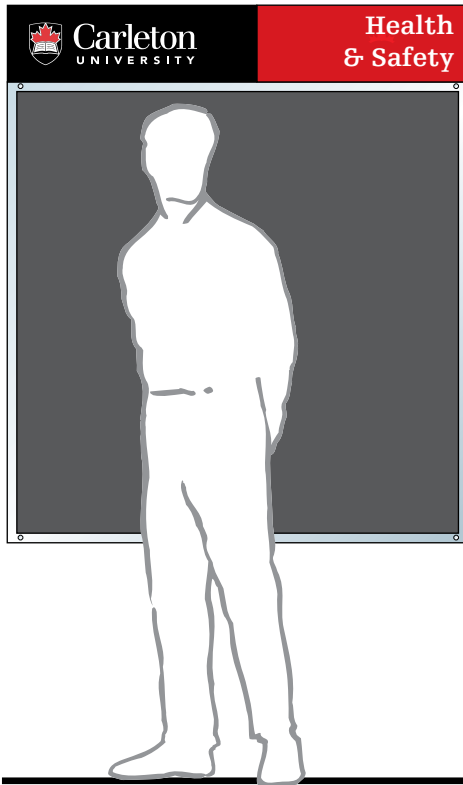

Bulletin Boards – 4', 6', 8'

- In 2 parts - header & boards
- Available in 3 lengths x 4' high.
- Boards are always dark gray tack surface with silver (natural aluminum colour) edging.
- Headers have black section with Carleton logo and coloured section in one of 4 colours: red, blue, ochre and green - with title/text in white.
- Header colour is red for general university information; colours are for departmental specific use (as per faculty colour assignment)

Locking Bulletin Boards – 4', 6'

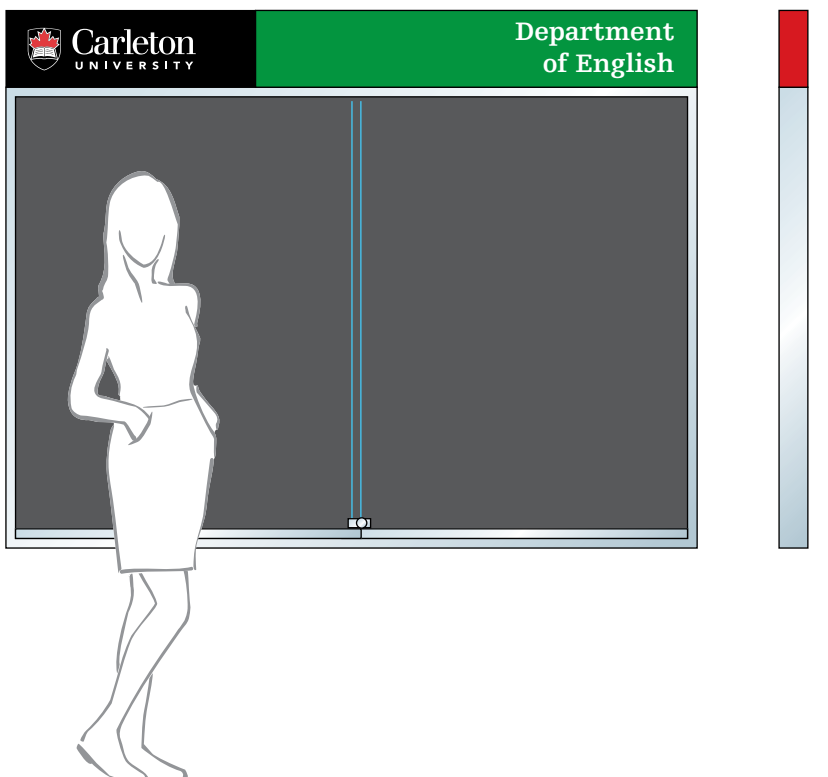
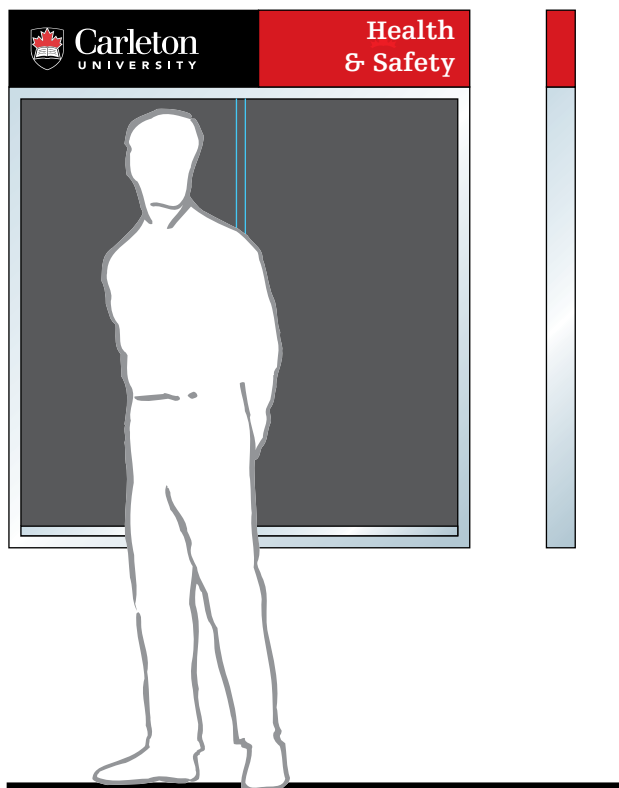

Locking Bulletin Boards – 4', 6'

- In 2 parts - header & boards
- Available in 2 lengths x 4' high.
- Boards are always dark gray tack surface with silver (natural aluminum colour) edging.
- Headers have black section with Carleton logo and coloured section in one of 4 colours: red, blue, ochre and green - with title/text in white.
- Header colour is red for general university information; colours are for departmental specific use (as per faculty colour assignment)

Display Showcases – 4', 6'

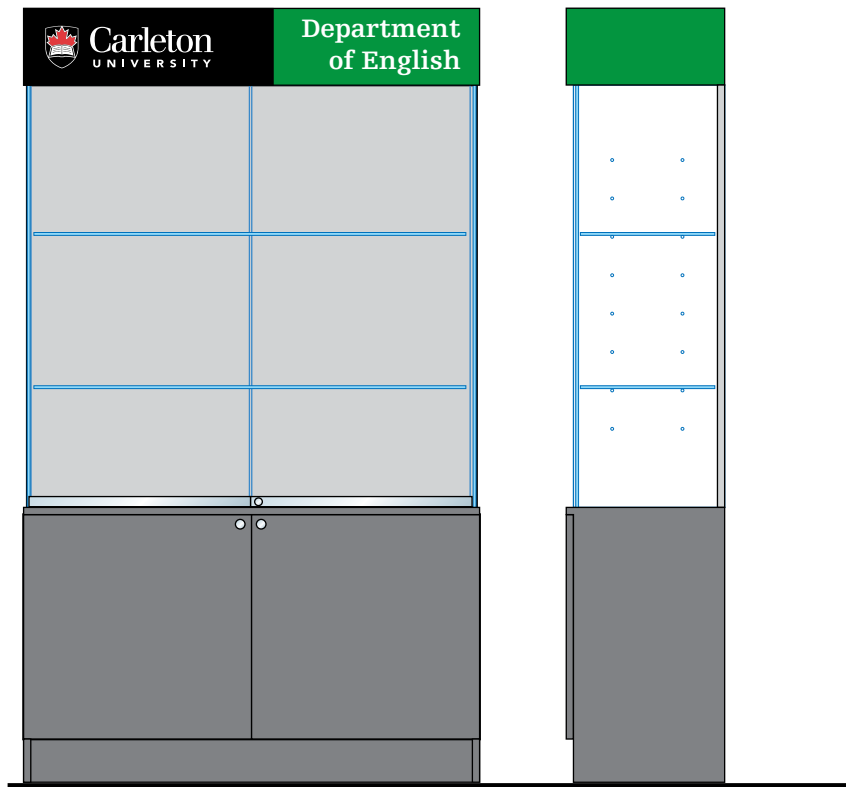

Display Showcases – 4', 6'

- Available in 2 lengths x 81" tall.
- Lower section has locking storage.
- All units are 16.5" deep.
- Glass display area has 2 adjustable glass shelves and locking sliding glass doors.
- Bulkhead (Header) has pot lighting.
- Headers have black section with Carleton logo and coloured section in one of 4 colours: red, blue, ochre and green - with title/text in white.
- Header colour is red for general university information; colours are for departmental specific use (as per faculty colour assignment)

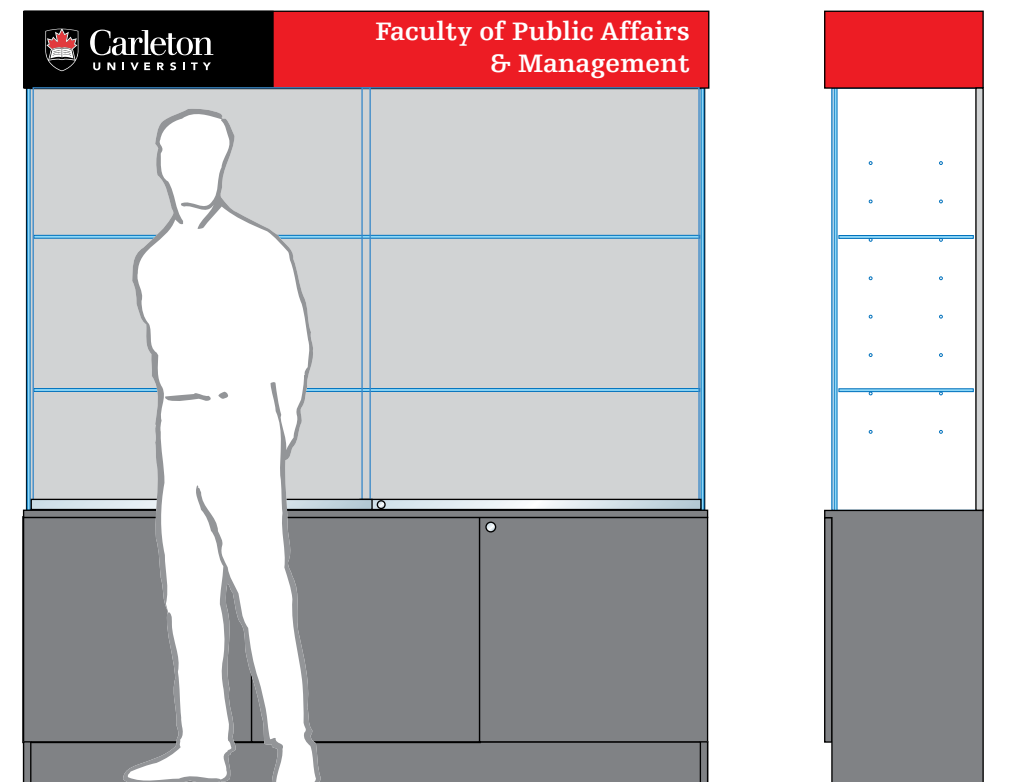

Faculty 3D Wall Lettering

School of Journalism and Communication



Faculty 3D Wall Lettering

- Brushed metal on 1/4" plastic lettering with edges painted silver.
- Attached to wall.
- On main wall with clear line of sight and not obstructed by columns, tall furniture etc. (can have low seating area & coffee table in front)
- Can be behind reception desk
- Must be at least 24" from door, adjacent wall, window etc. on both sides

School of Studies in Art and Culture

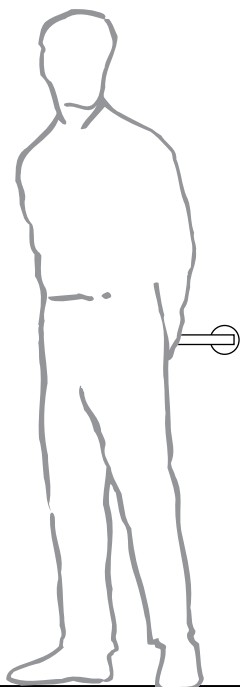

Enhanced Overhead Signs

Enhanced Overhead (Door) Signs

- Dimensional stainless steel lettering on painted aluminum red bar.
- Attached to wall over doorway, etc.
- Ensure height above door allows for installation/clearance.

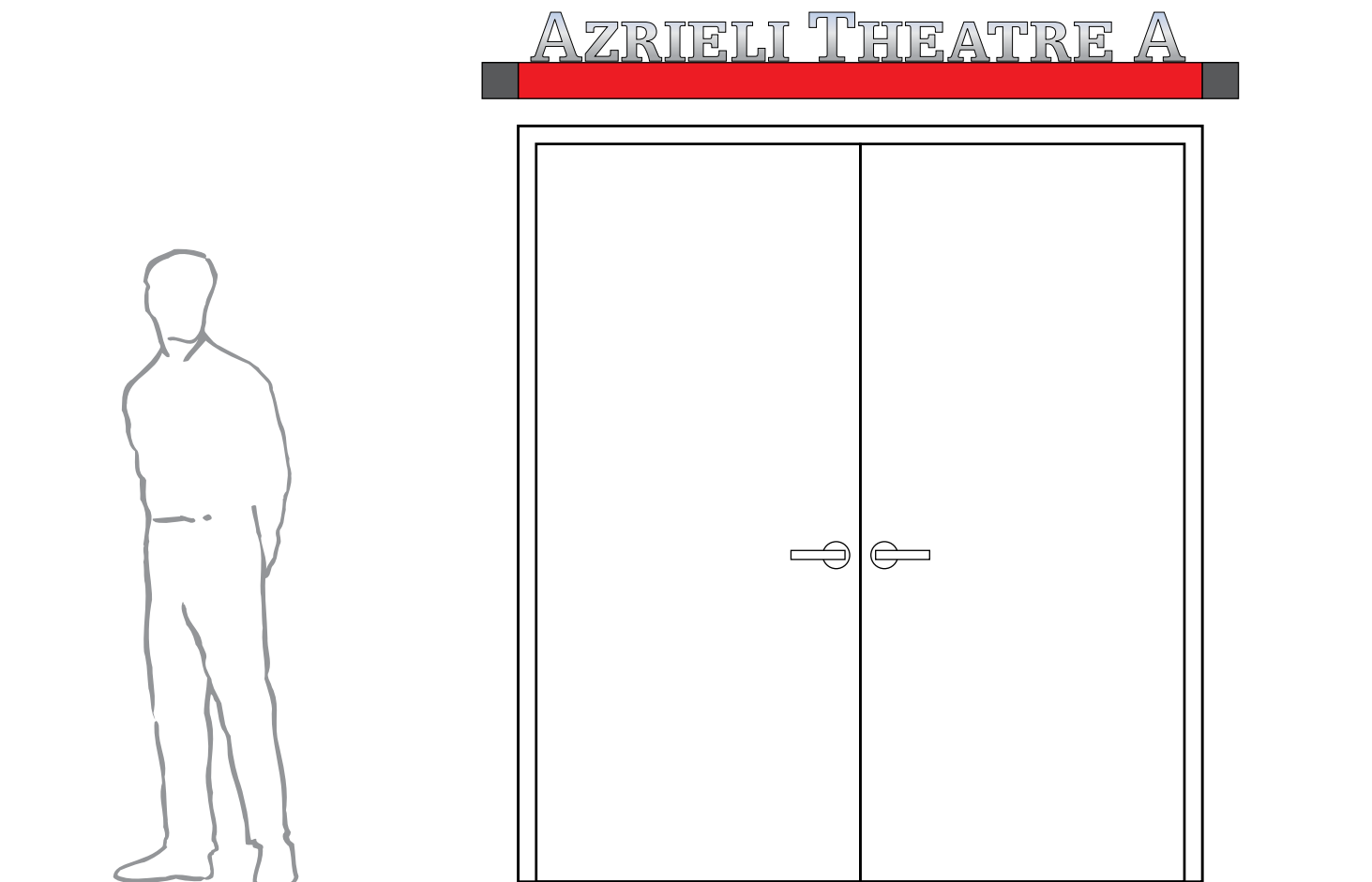

Outdoor Sandwich Boards

Outdoor Sandwich Boards

- Red painted thin marine-grade plywood hinged sandwich board for temporary outdoor (road & pathway) announcements and directions.
- Held open with fixed chain.
- Messaging in vinyl text on disposable "coroplast" sheet, screwed to face(s)
- Single or double-sided.

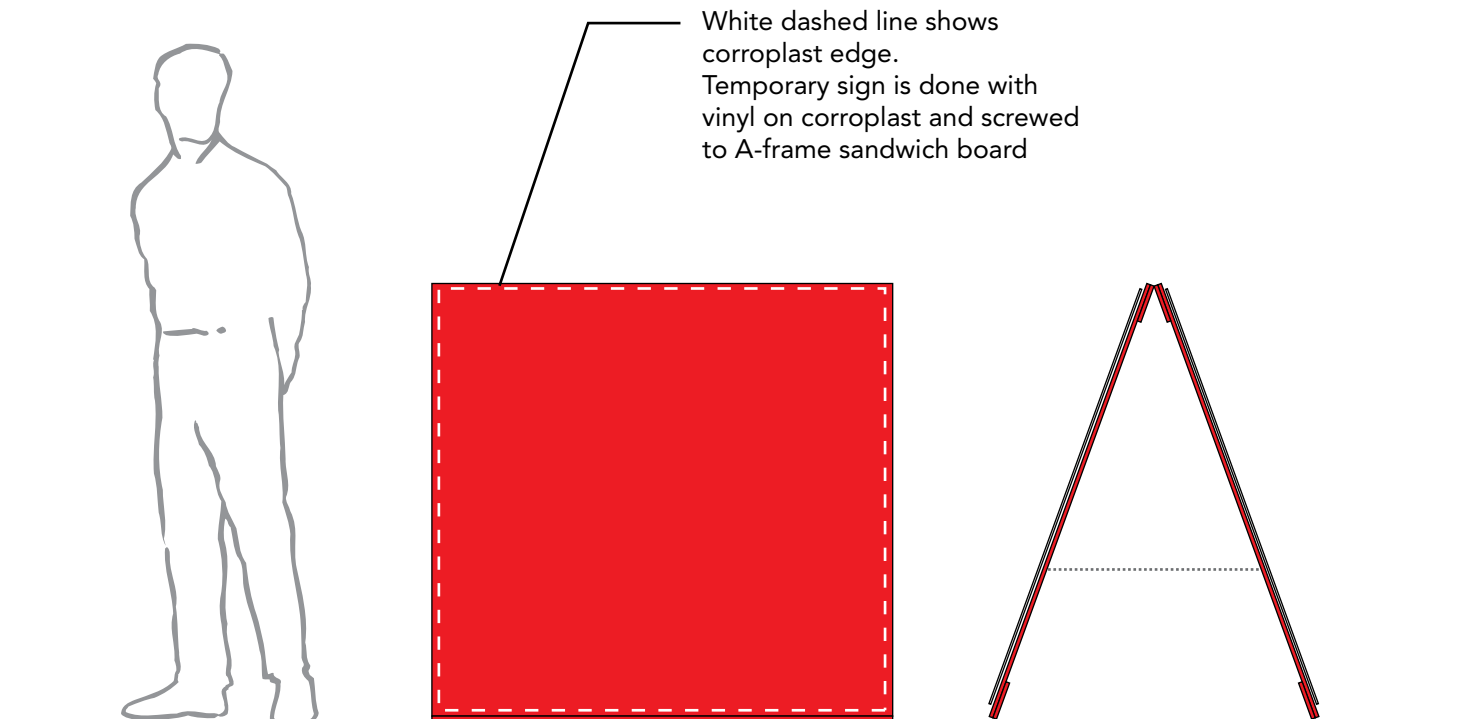

Wall Mounted Literature Rack

Wall Mounted Literature Rack

- Holds 22" (running) of literature; up to 11" tall
- Stackable - 4 will stack next standard bulletin board
- Made n also be used linearly, 2 unde
- r 4'
- Screwed to wall (4 screws)
- Back panel is clear - minimal presence when empty
- see pages D.3.5 & D.5.5 (there are no applicable graphics to this unit)

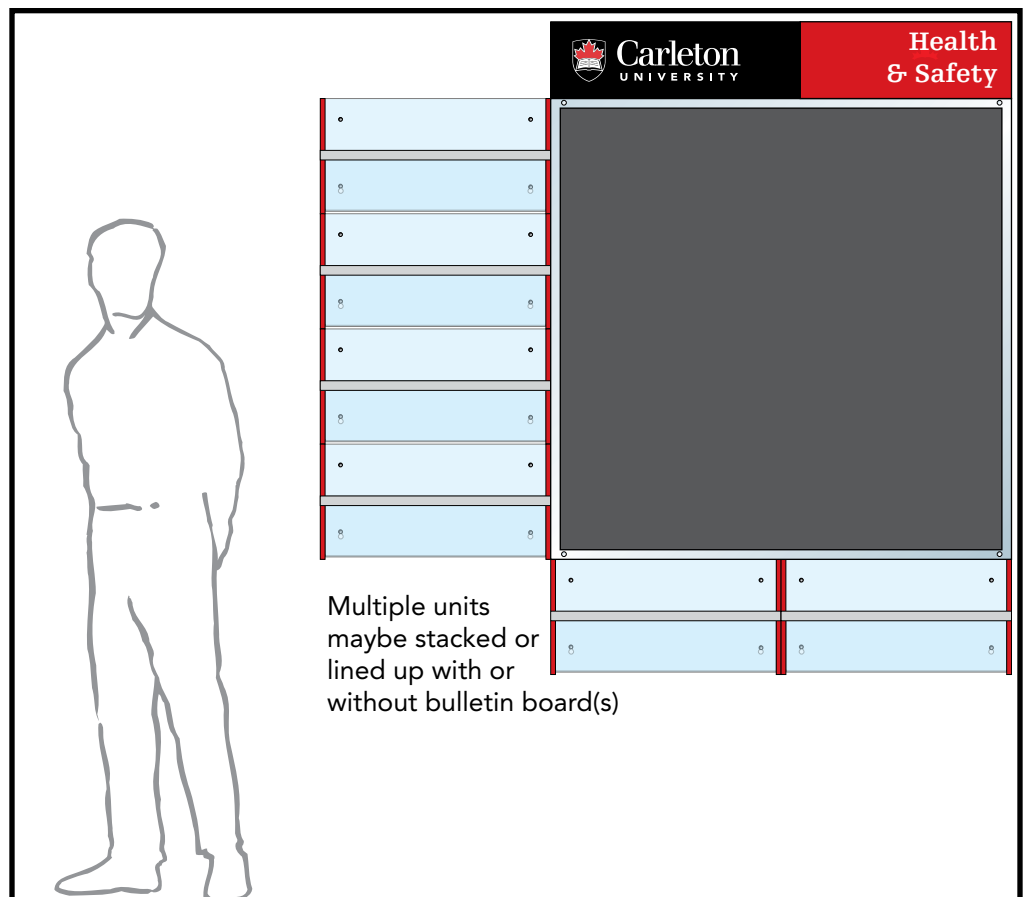
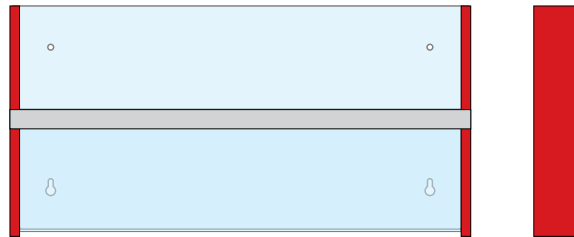
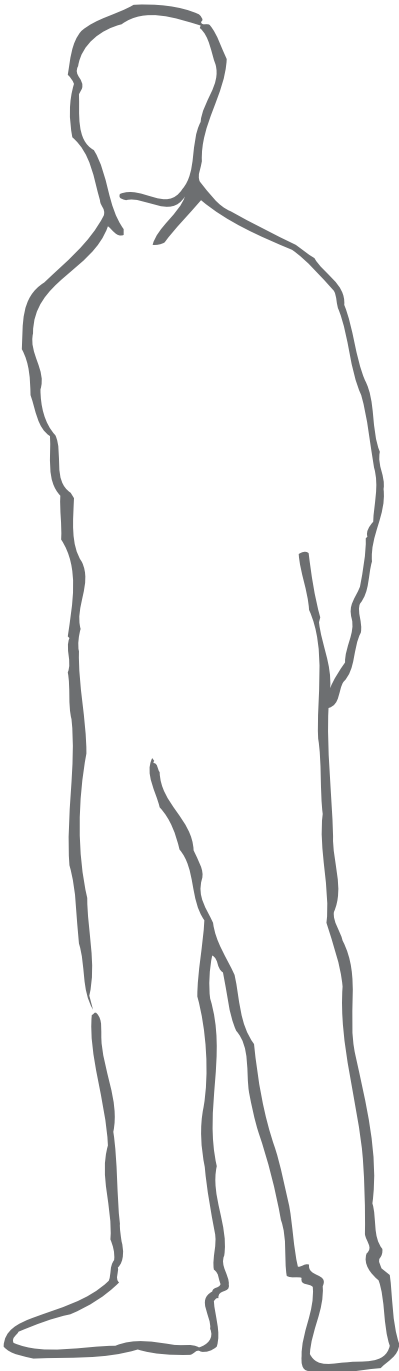

Free Standing Poster Holder

Free Standing Poster Holder

- Single or double sided versions available
- Available with or without literature rack attached on bottom (see page D.2.7)
- Holds 24" x 36" posters (or smaller)
- Consider pedestrian traffic flow and tripping hazard issues when using
- Logo or text at top - see page D.4.8
- see pages D.3.5 for dimensions

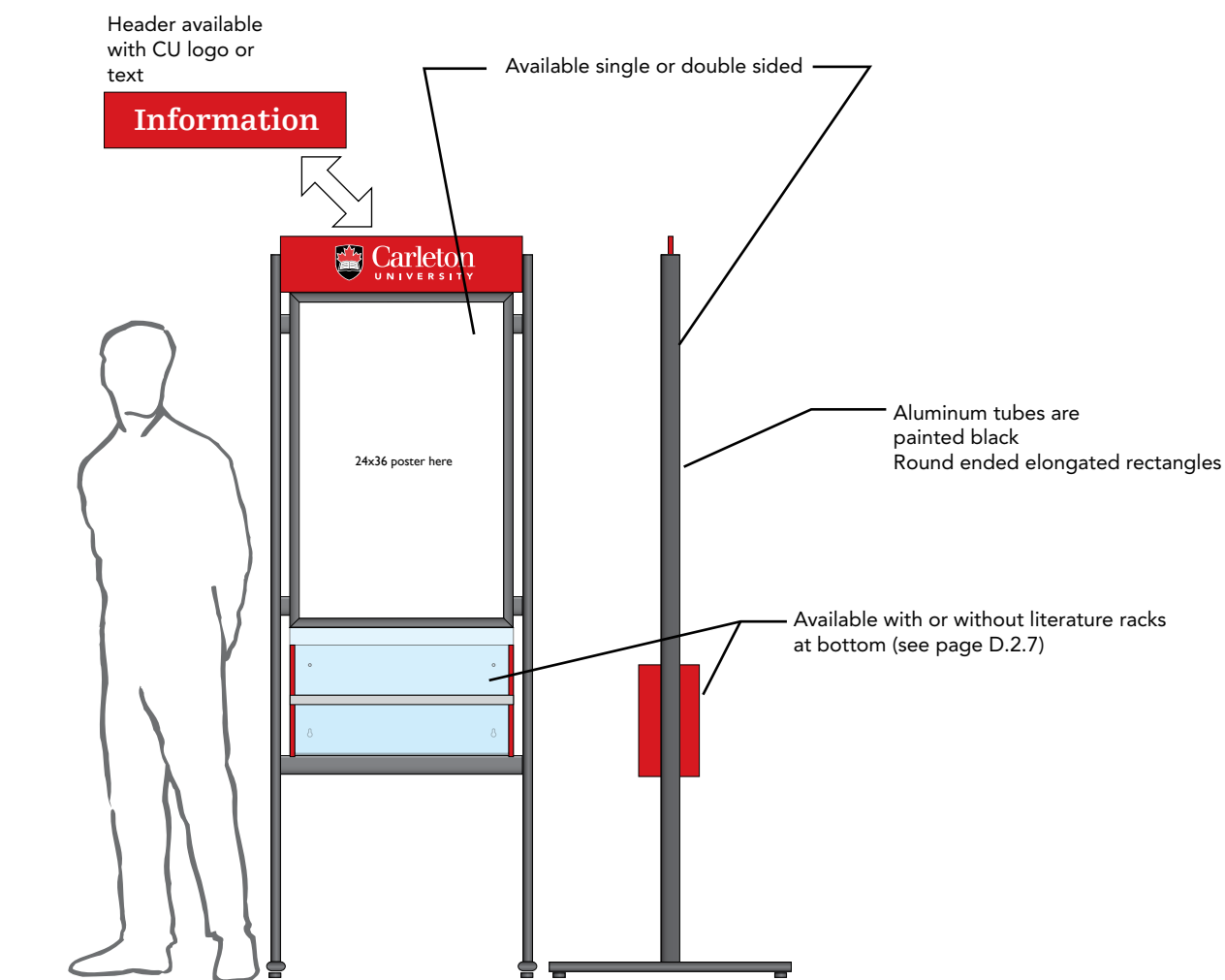

Bulletin Boards – 4', 6', 8'

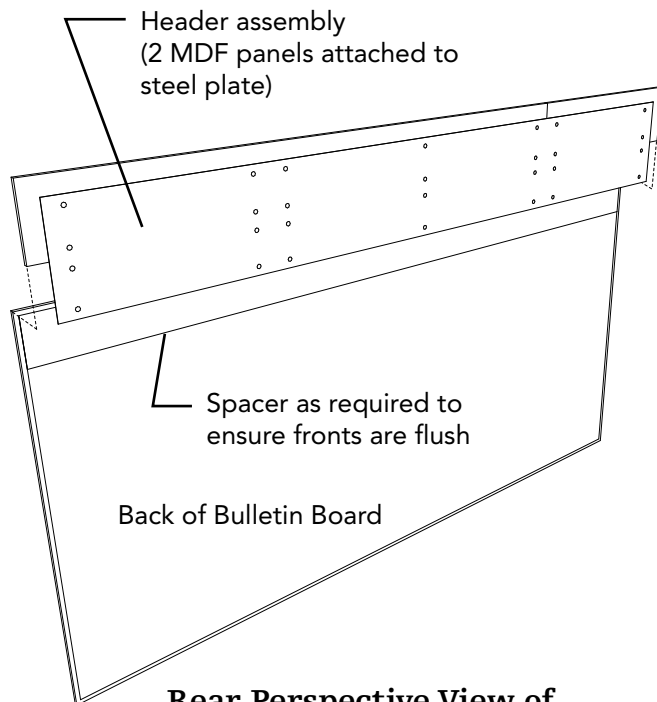
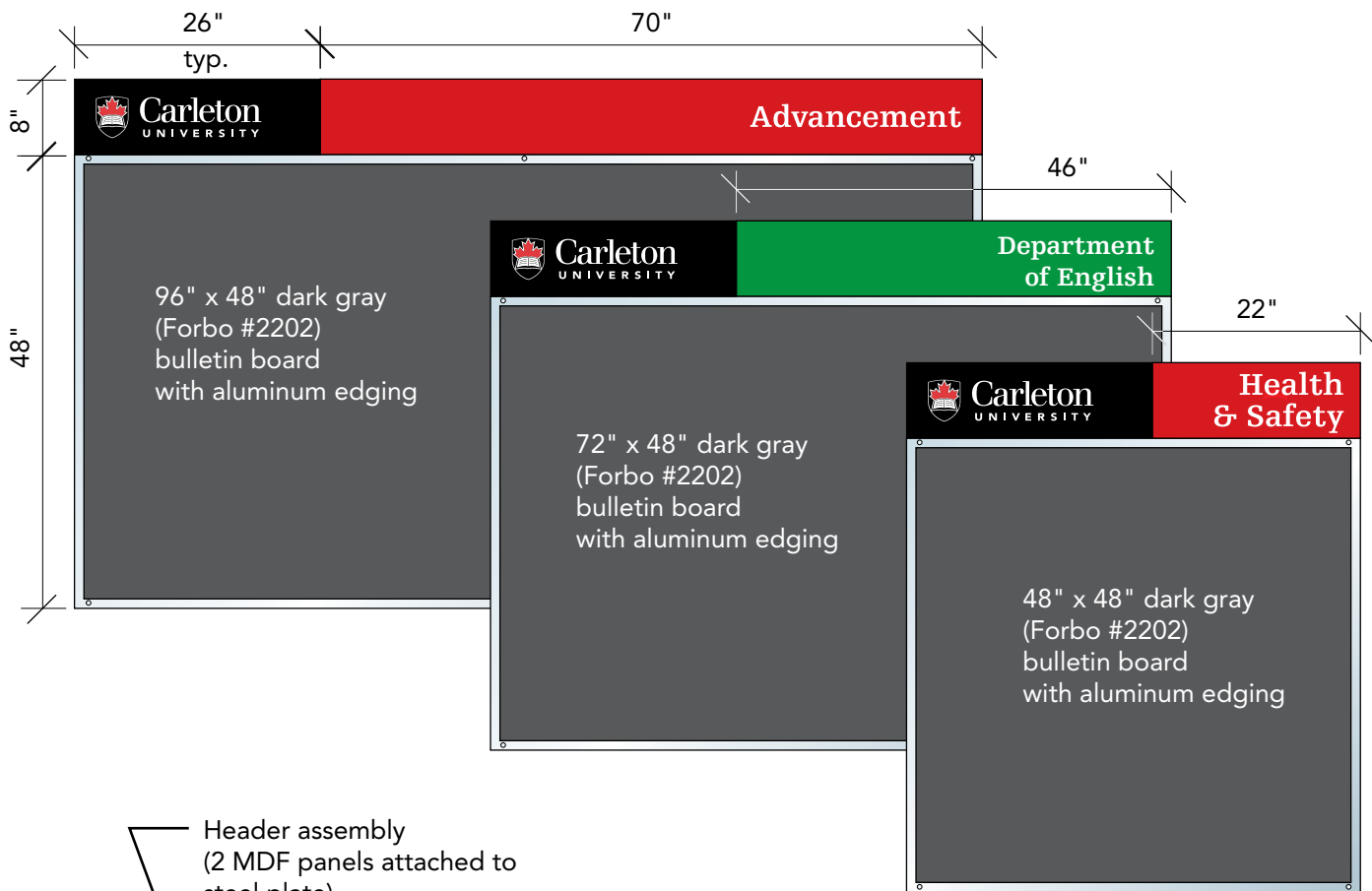

Rear Perspective View of Header Assembly and Bulletin Board - Typical - (96" Board & Header Shown)

Bulletin Boards – 4', 6', 8' Details

- Board is to be purchased as complete bulletin board (aluminum frame in clear anodized finish, backer and Forbo #2202 synthetic tack surface) from outside supplier. Contact Physical Plant for current supplier.
- Header is 2 pieces of 1/2" MDF painted (semi-gloss) with Carleton logo screen-printed in epoxy inks on black part and white vinyl (premium grade) on colored part.
- Header is bonded and screwed (#8x1/2") to custom 18ga. mild steel panel c/w holes.
- Header assembly is attached to bulletin board with adhesive and screws (#8x3/8") - masonite spacer may be required depending on thickness of frame extrusion.
- Front surface of header to be flush to front of aluminum frame.

Locking Bulletin Boards – 4', 6'

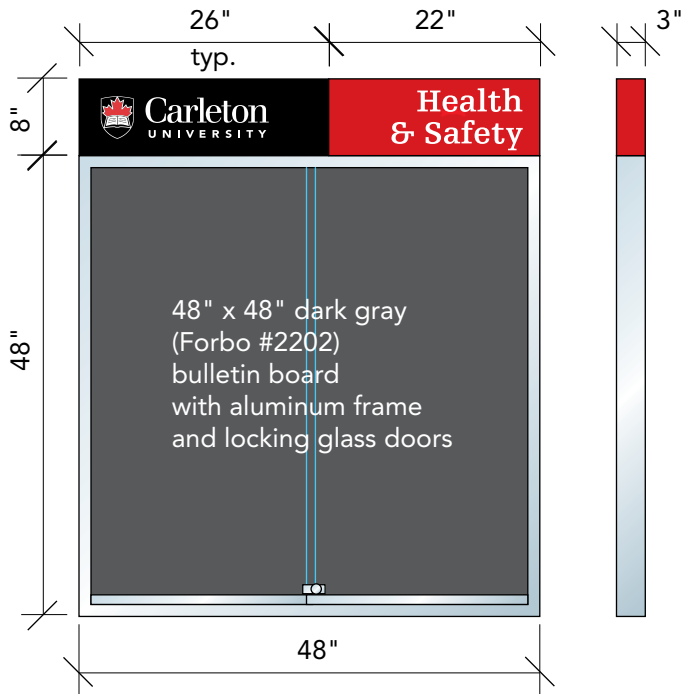

Locking Bulletin Boards – 4', 6' Details

- Board is to be purchased as complete bulletin board (aluminum frame in clear anodized finish, backer and Forbo #2202 synthetic tack surface) from outside supplier. Contact Physical Plant for current supplier.
- Header is 1 piece of built-up MDF covered p.lam. (Formica 909-58 black & 845-58 spectrum red) with Carleton logo screen-printed in epoxy inks on black part and; white vinyl (premium grade) on coloured part.
- Header is attached to wall at time of installation via internal hidden split baton.
- Header is secured with screws (3) from inside top of frame into header.

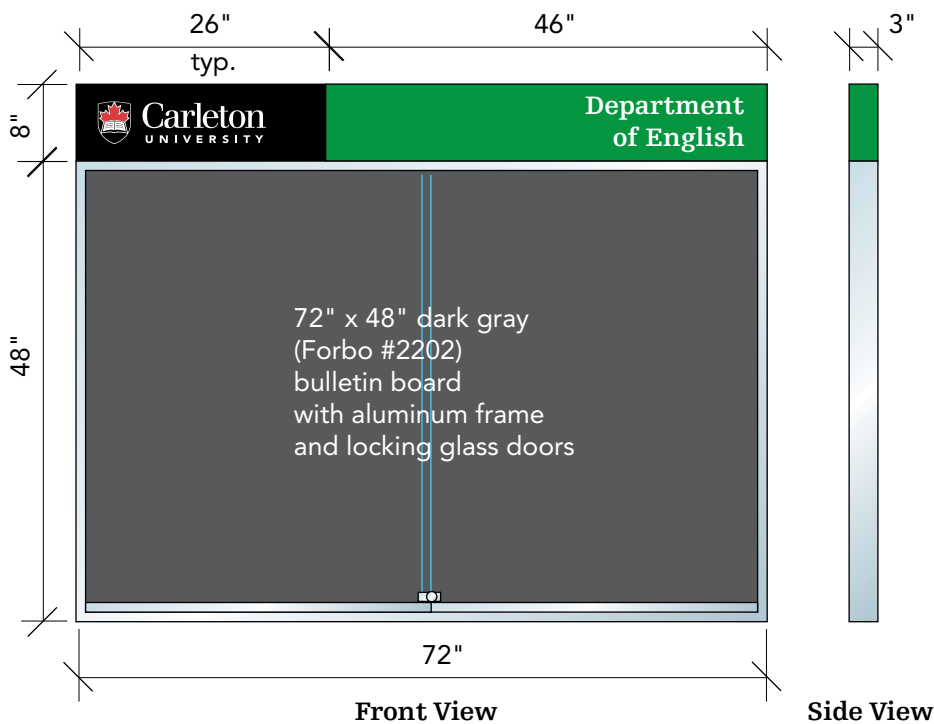

Display Showcases – 4', 6'

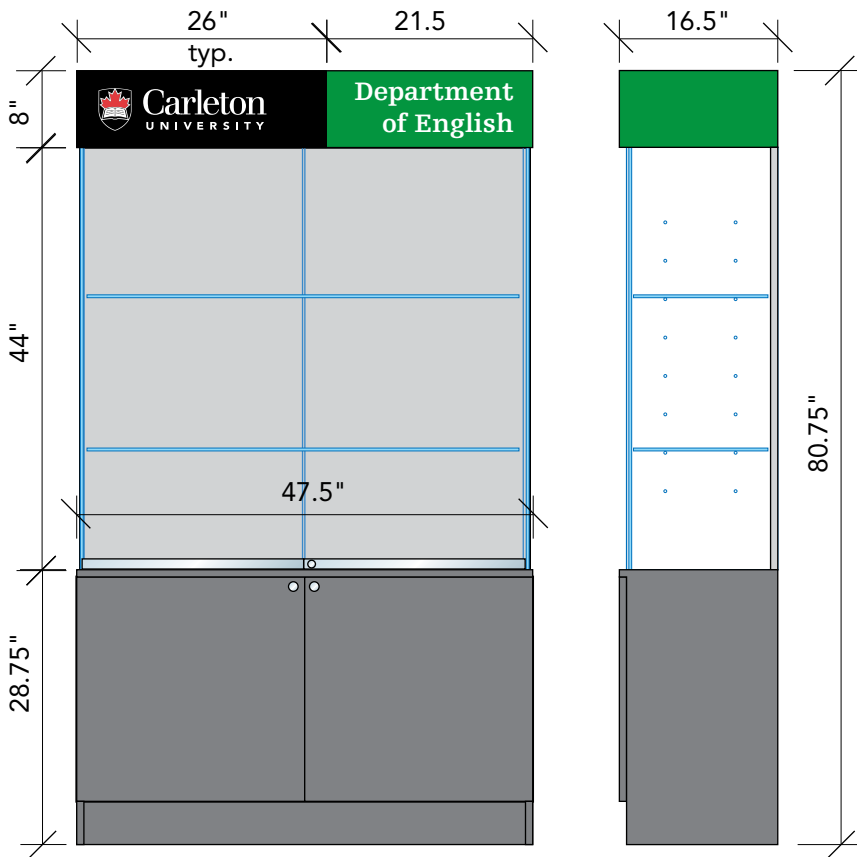

Display Showcases – 4', 6' Details

- Showcase is to be purchased as unit (Header with lighting, glass case with locking doors, millwork base with locking doors) from outside supplier. Contact Physical Plant for supplier.
- Header is covered with p.lam. (Formica 909-58 black & 845-58 spectrum red; other colours to match Carleton colours) with Carleton logo screenprinted in epoxy inks on black part and white vinyl (premium grade) on coloured part.
- Interior of glass area covered with light gray p.lam. (Formica 927-58 folkstone)
- Lower cabinet is covered with dark gray p.lam. (Formica 912-58 storm)

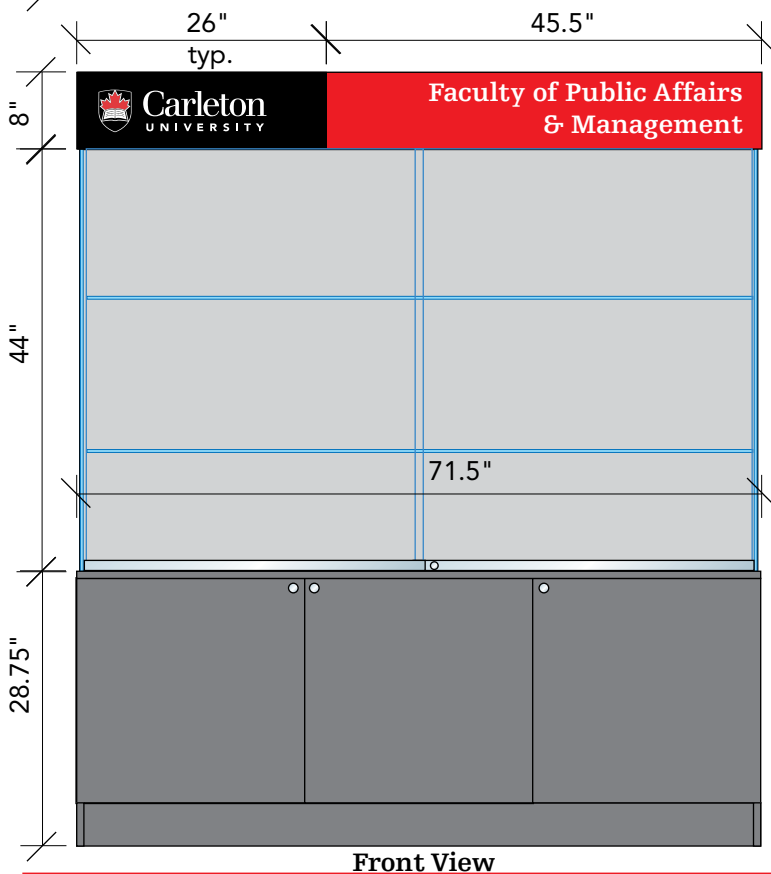

Front View

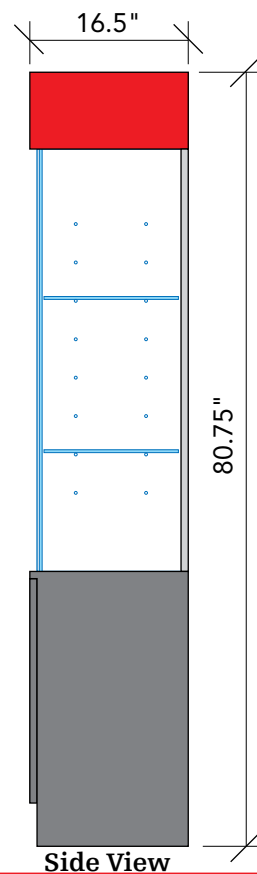

Side View

Faculty 3D Wall Lettering



Faculty 3D Wall Lettering Details

- Solid metal laminate (eg Octolux BRU 1) with brushed aluminum finish on 1/4" thick acrylic or plastic with edges painted silver.
- Back of letters to have 3M #4026 double sided foamtape trimmed to fit. Tape cannot be closer than 1/8" to edge of letters.

School of
Studies
in Art and
Culture

Enhanced Overhead Signs

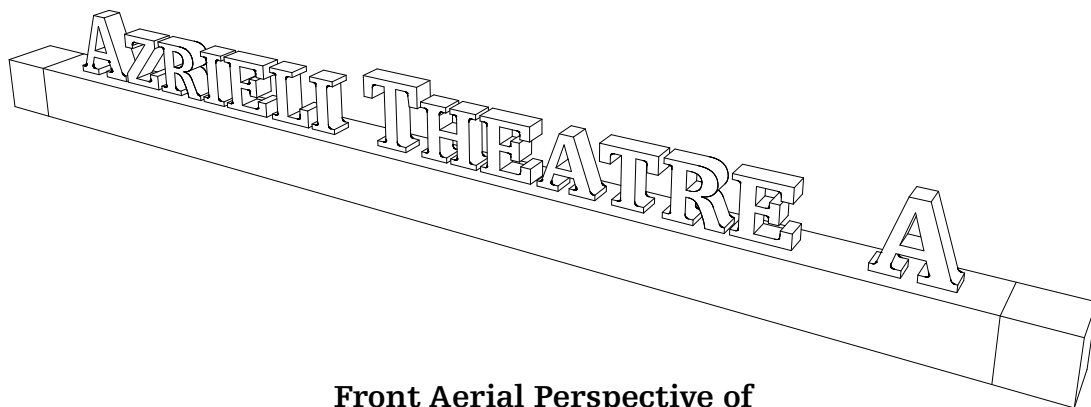

**Front Aerial Perspective of
Enhanced Overhead Sign**

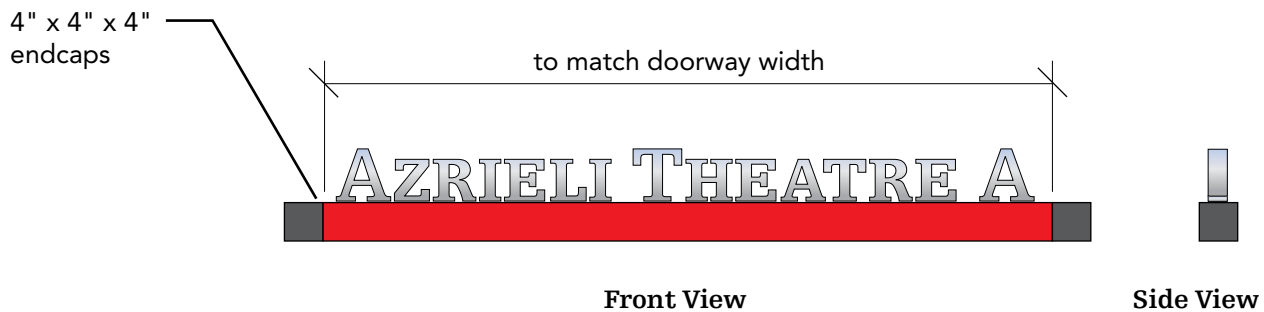

Enhanced Overhead (Door) Signs Details

Lettering

- Approximately 5.5" (larger) and 4.375" (smaller) small cap text in stainless steel channel lettering.
- Finish of lettering is horizontal brush on front.
- Lettering secured to red bar with minimum 2 bolts per letter, to prevent spinning.

Red Bar with Gray caps

- 4" x 4" (x length) aluminum extrusion with channel in back for wall bracket - powder coated red - semi-gloss.
- 4" x 4" x 4" aluminum extrusion with welded endcap (one side) - powder coated dark gray - gloss.
- Bolt stainless letters along centre line on top of red bar - with slot facing back
- Permanently attach caps to bar.

Outdoor Sandwich Boards

Outdoor(A-frame) Sandwich Boards (for temporary announcements) Details

A-Frame

- 4' x 8' x 3/8" marine grade plywood (to resist moisture) - cut into 2 - 4' x 4' panels.
- Reinforce top & bottom edges with 4" strip of same plywood.
- Paint entire frame red.
- Join at top edge with stainless steel continuous hinge.
- Install 24" long chain - 16" up from bottom to connect both sides.
- use bolts + washers through face

White dashed line shows coroplast edge.
Temporary sign is done with vinyl on coroplast and screwed to A-frame sandwich board

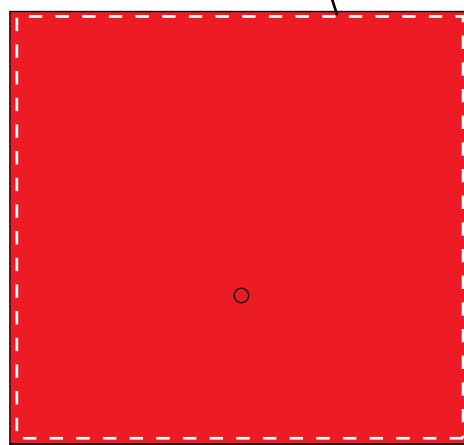
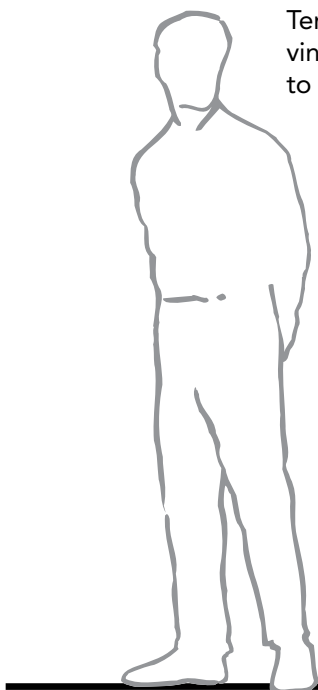

Front View

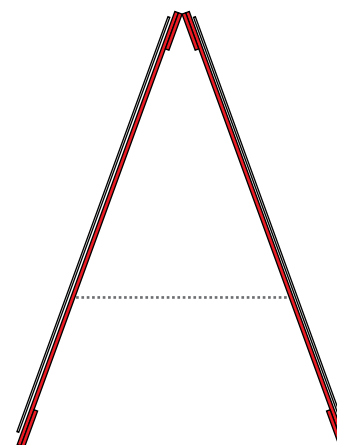

Side View

Wall Mounted Literature Rack

Wall Mounted Literature Rack

Details

- Purchased as finished units.
- Made from polycarbonate, acrylic and aluminum.
- Folded rack is 3/16" folded polycarbonate; ends are 0.72" (± 0.02) acrylic (painted CU red - PMS 186C); 1" satin anodised aluminum trim
- 4 installation holes - lower two are keyholes to slide down onto; top screws lock lower ones down.

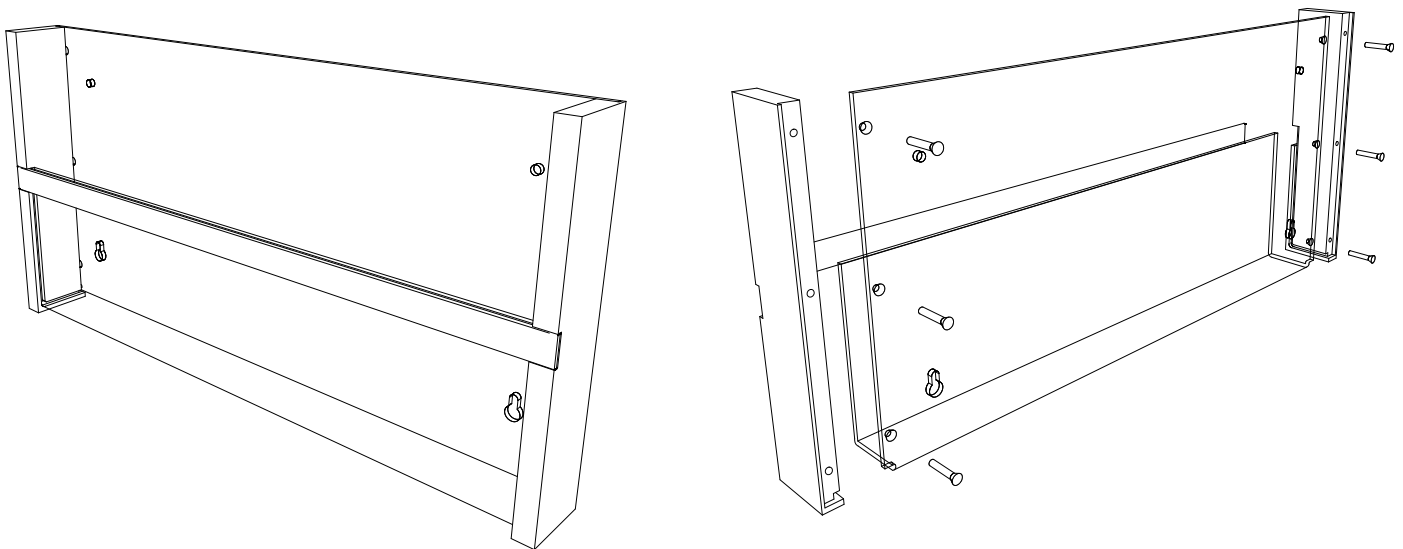
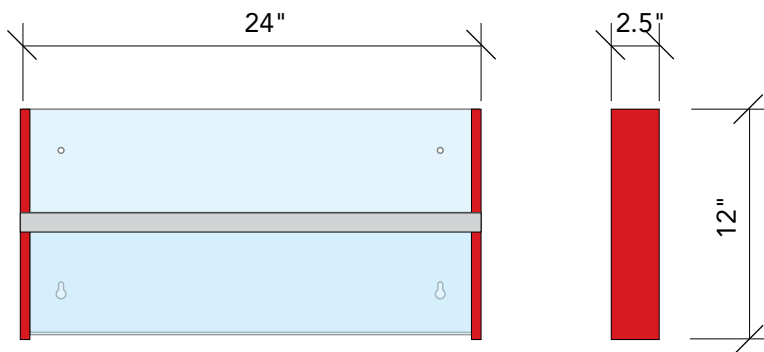

Free Standing Poster Holder

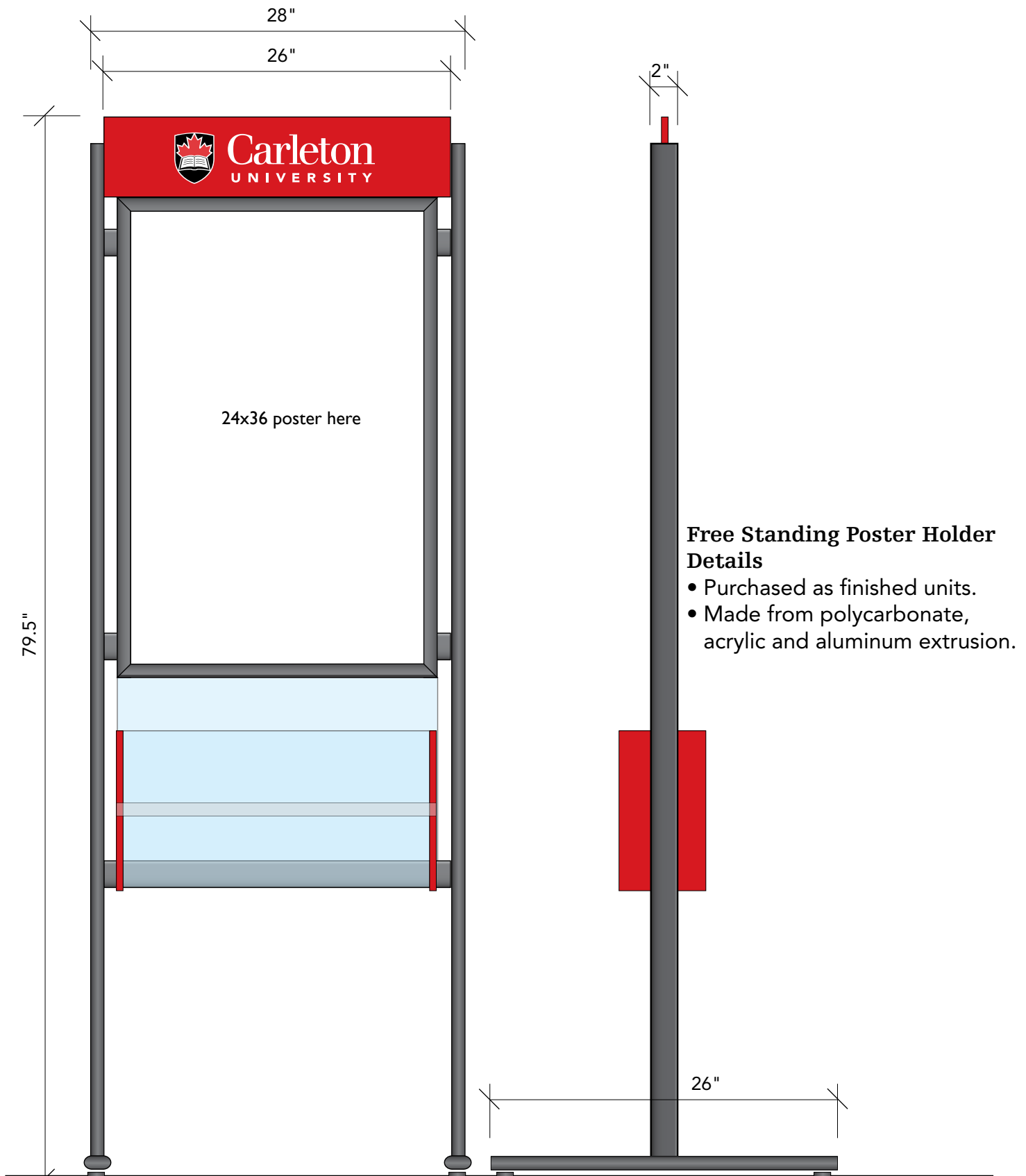

Bulletin Boards, Locking Bulletin Boards & Showcases

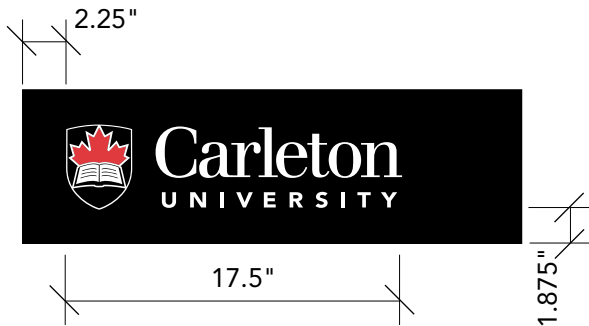

Egyptienne F 75 Black
- 200pt on 240pt leading
Maximum 1 lines of text



Egyptienne F 75 Black
- 200pt on 240pt leading
Maximum 2 lines of text

Faculty 3D Wall Lettering

Egyptienne F 75 Black
- 600pt on 600pt leading
Maximum 4 lines of text

**School of
Journalism
and
Communication**

Enhanced Overhead Signs

Egyptienne F 65 Bold
- 600pt for Large Letters (suggested - see note below)

Egyptienne F 75 Black
- 480pt for Small Letters (suggested - see note below)

AZRIELI THEATRE A

Special Note for Typography on Enhanced Overhead Door Signs:

- Due to unpredictable word lengths, especially when there are multiple (but different text) signs of this type in the same facility, there will have to be adjustments made in the font size and tracking to fit text while maintaining visual consistency. This is especially true if two sign (or more) signs can be seen at the same time.
- It is recommended that the names be kept short and of the same character count in a multi-sign facility.
- The graphic designer should fit all the sign text onto scaled red bars (1/10 scale is good) as a test and adjust from there. Including changing the font size if required.
- Also all doorways (and other opening where signs are to go) should be measured rather than assumed to be 72", etc.

Free Standing Poster Holder

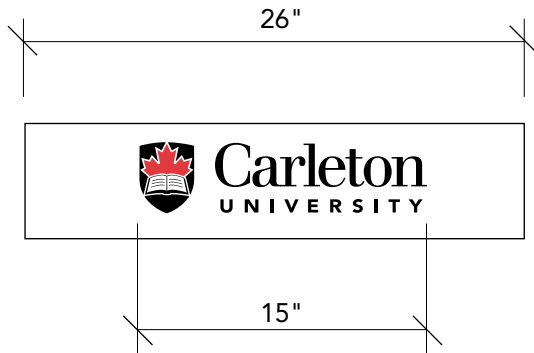

In white, black and red vinyl (PMS 186C)

Information

White vinyl - Single Line:
Egyptienne F 65 Bold
- 240pt

**Information
at Carleton**

White vinyl - Two Line:
Egyptienne F 65 Bold
- 200pt on 200pt leading

Bulletin Boards – 4', 6', 8'

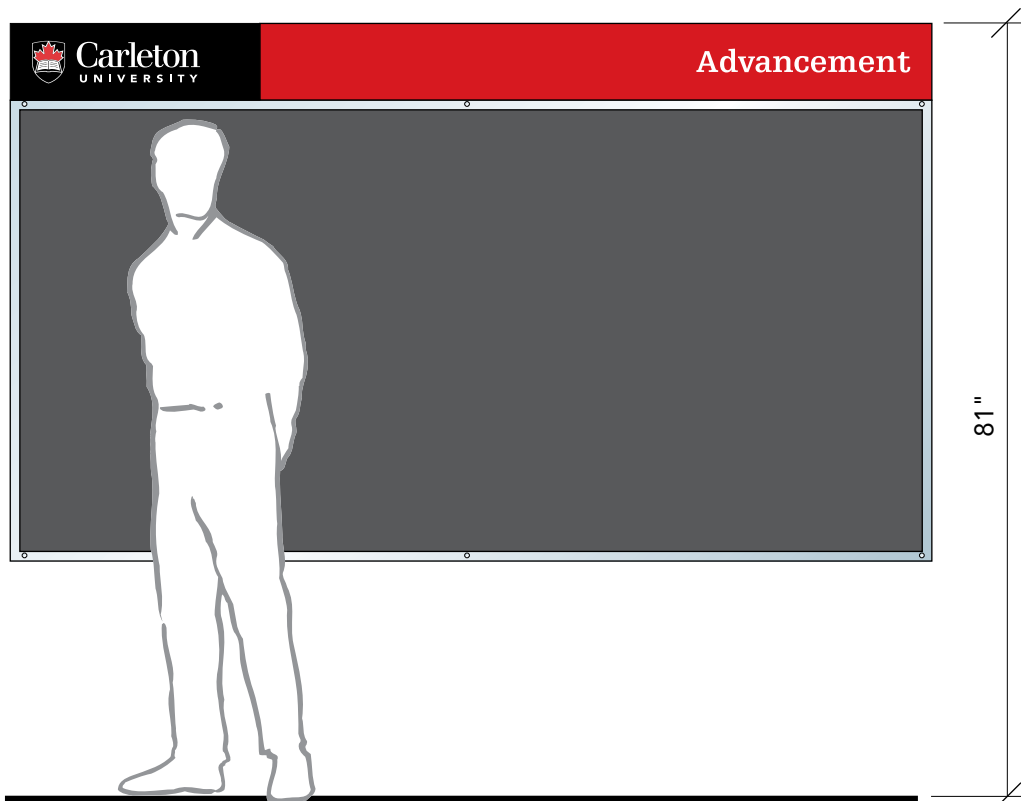
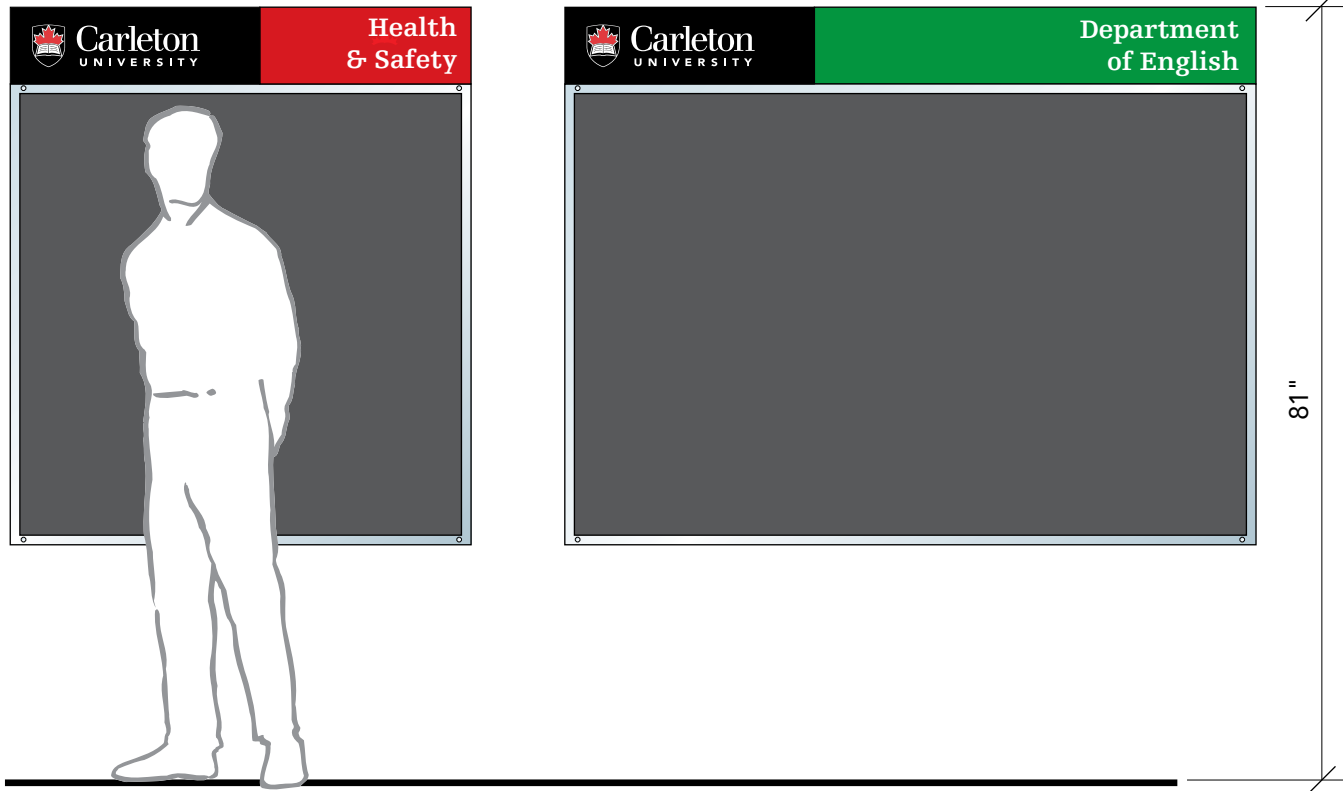

Bulletin Boards – 4', 6', 8' Installation

- Header mounted to board ahead of install.
- Screw board part to wall (use appropriate screw/washer/anchor combination).
- 4 screws (minimum) for 4' & 6' boards
- 6 screws (minimum) for 8' board
- Do not over torque screws (frame will compress)

Locking Bulletin Boards – 4', 6'

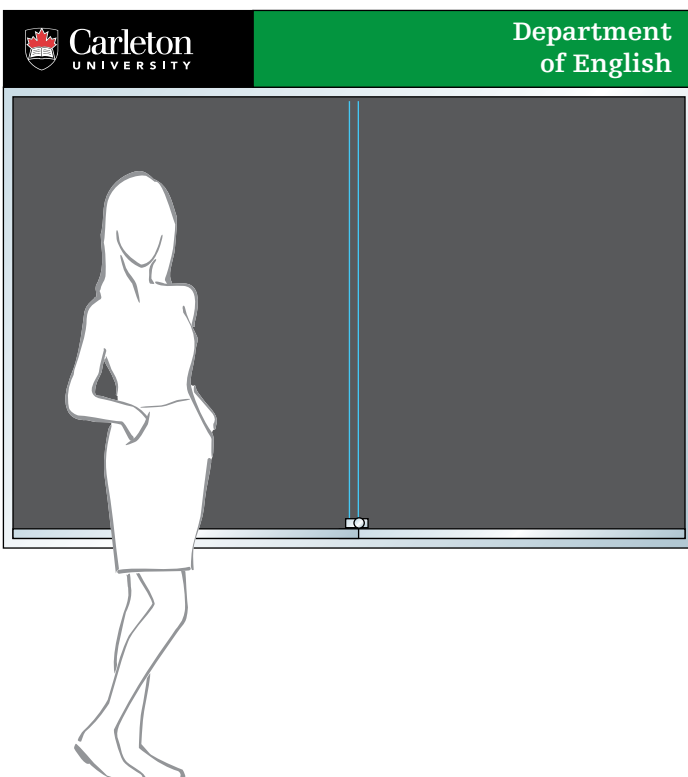
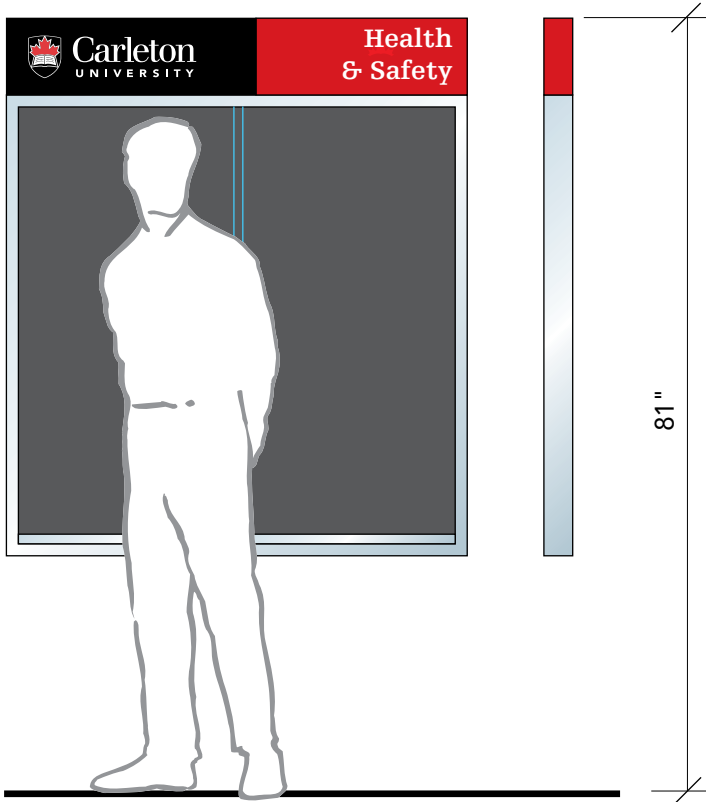

Locking Bulletin Boards – 4', 6' Installation

- Header mounted to board after install of board.
- Screw board part to wall (use appropriate screw/washer/anchor combination)
- Preferred screw location is behind tack surface (if corners left loose, or can be loosened) in corners of board
- 6 screws for (minimum) 4' & 6' boards
- Do not over torque screws (back will compress)
- Header is attached to wall at time of installation via internal hidden split baton.
- Header is secured with screws (3) from inside top of frame into header.

Display Showcases – 4', 6'

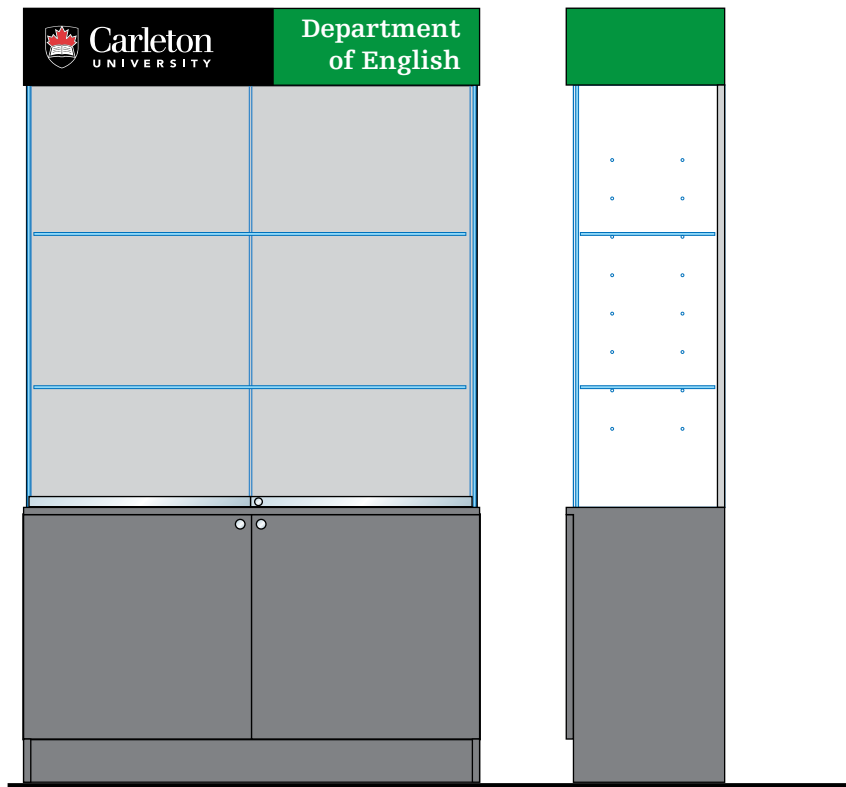

Display Showcases – 4', 6' Installation

- Position on floor, against wall
- Adjust leveling feet if required (use level)
- Screw through header/bulkhead (inside) into wall - using appropriate screw/anchor combination. This step is to ensure showcase does not topple and provides some theft (removal) protection

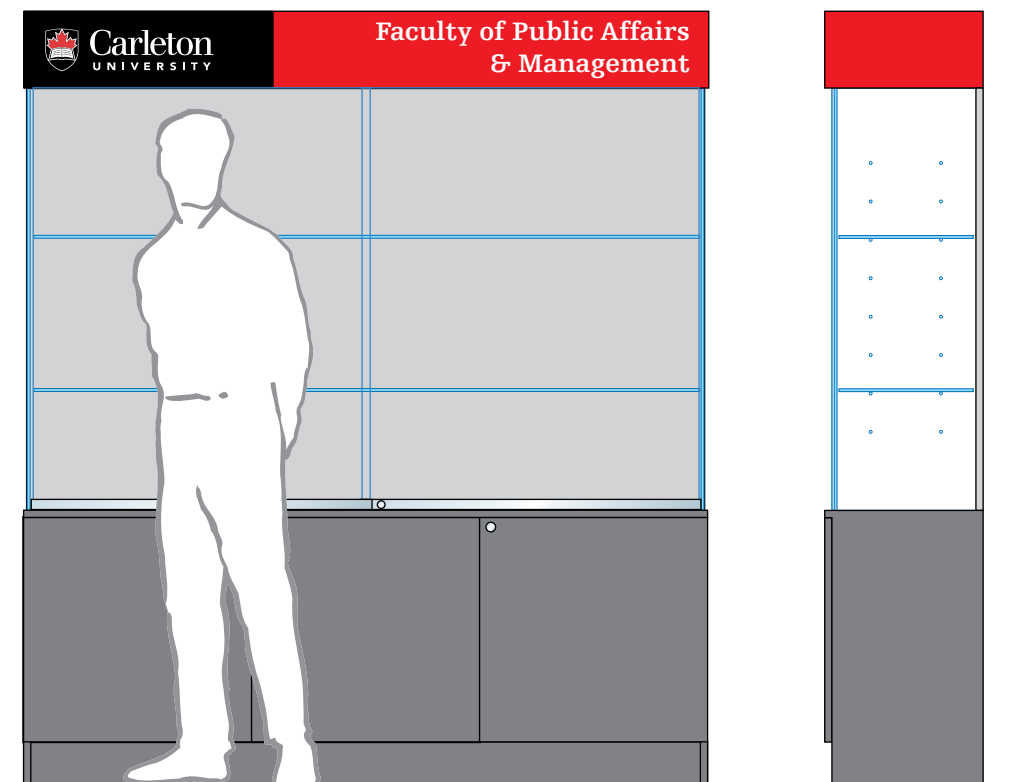

Faculty 3D Wall Lettering

School of
Journalism
and
Communication



84"

Faculty 3D Wall Lettering Installation

- Ensure wall surface is properly prepared - clean, dry and level. If wall has recently been painted, ensure that the paint has been allowed to dry for a minimum of 2 days, prior to installation.
- Apply lettering to wall with double sided foamtape. (use only 3M products, #4026 is recommended)
- Consult 3M documentation to ensure all installation conditions are met and proper technique/procedure is used.
- Use level and template to ensure proper letter spacing.

School of
Studies
in Art and
Culture

*24"

*minimum
- on both sides

84"

Enhanced Overhead Signs

Enhanced Overhead (Door) Signs Installation

- Install wall anchoring bracket to wall
- Slide sign assembly onto bracket and insert locking screws.

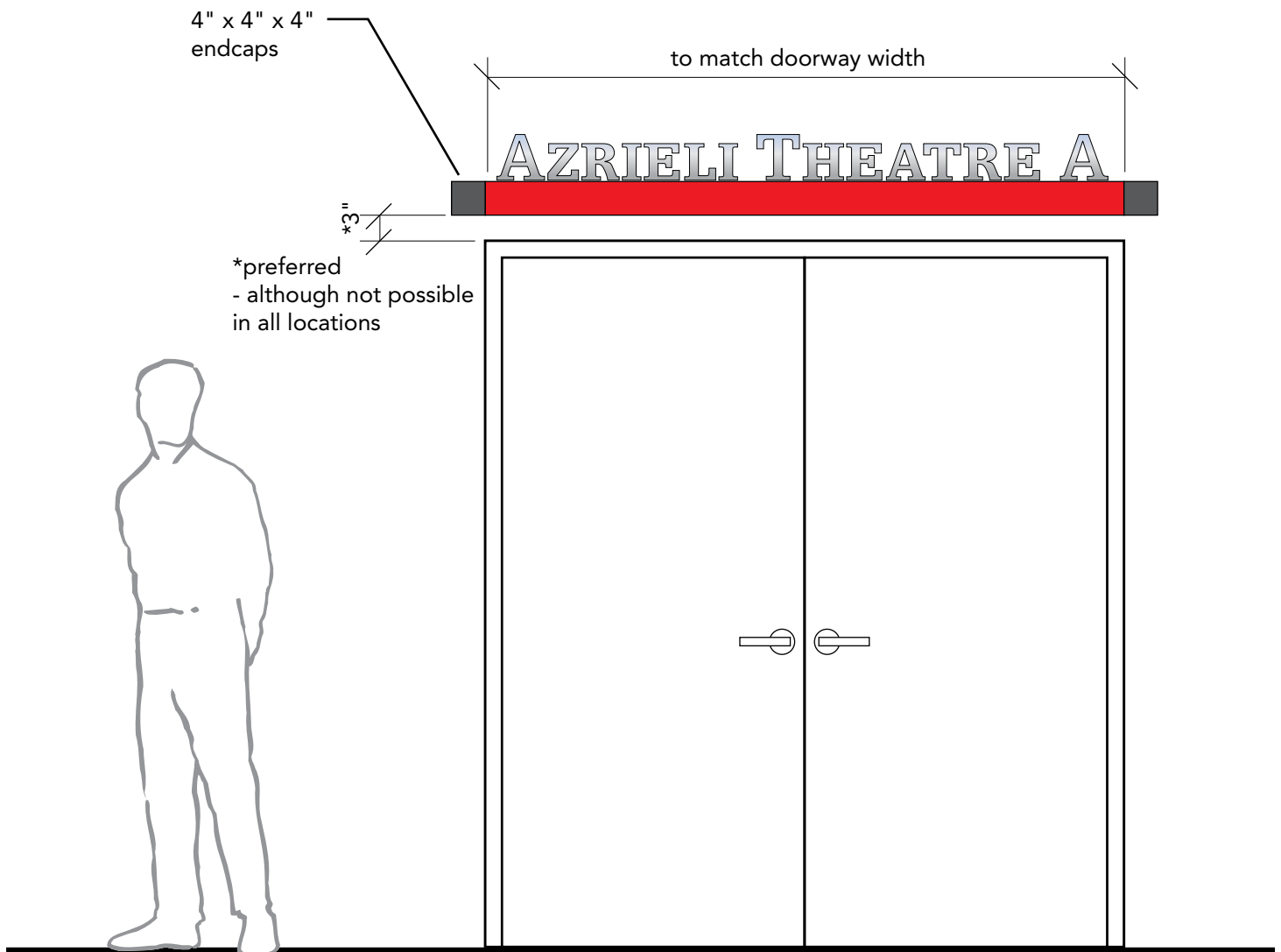

Wall Mounted Literature Rack

Wall Mounted Literature Rack

Installation

- Mark hole locations - ensure level.
- Use drywall anchors - zip-type.
- Install 2 lower screws
- Slide rack over screws on keyholes.
- Install upper screws to secure rack to wall.
- Do not over torque screws - lower screws will have to be set loose in order to slide keyholes over.

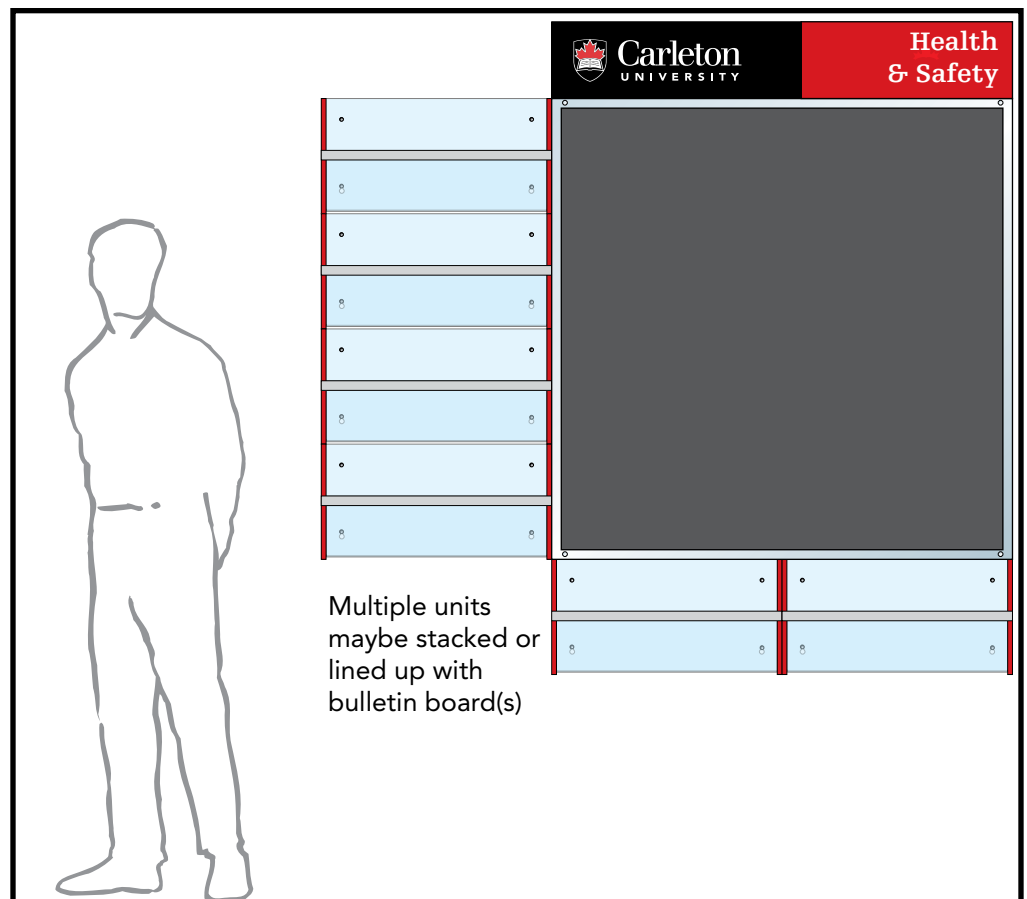
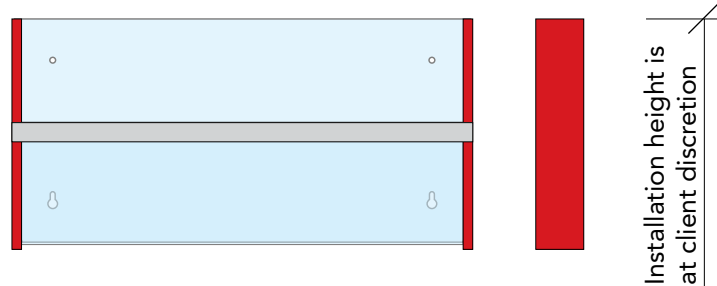
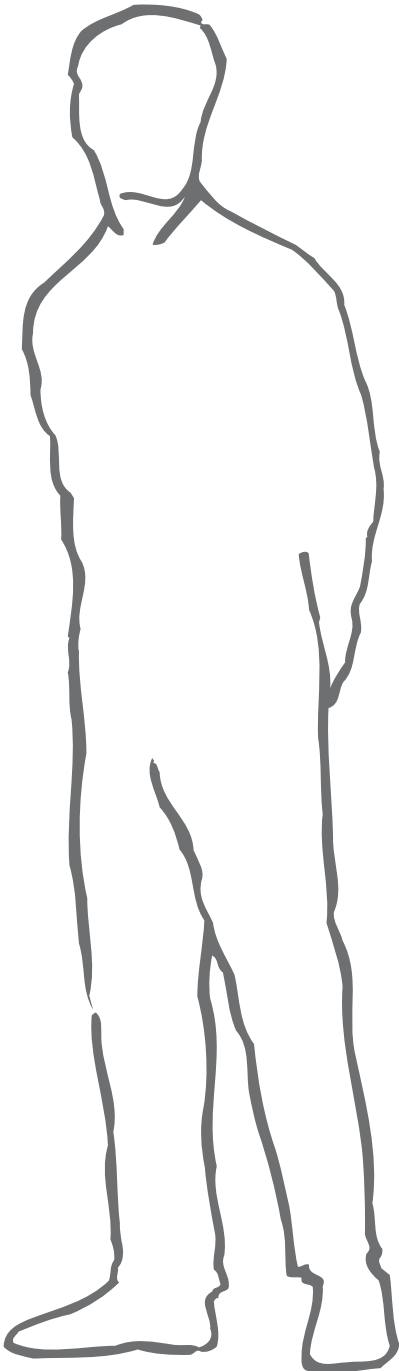

Cleaning

- All interior signs should be cleaned periodically – especially those in dusty environments.
- Cleaning for all signs should be done with a damp soft rag and mild, non-abrasive soap. Do not use paper towels as they will leave more particles behind and could scratch the sign surface.
- All signs with vinyl text should be wiped gently as vinyl text can be damaged/removed by excessive rubbing.

Removal of Paint due to Vandalism

- Some painted vandalism may be removed with solvents. The acrylics with textured surfaces will withstand small amounts of 'rubber cement' thinner and P95 can resist stronger solvents such as acetone.
- Always test solvents prior to use on any surface as most solvents will damage sign surfaces or inks.