

# Chapter 5

## Rigid Body Displacements

### 5.1 The Isometry Group

A mapping is a functional relation from the set of elements in the domain to the set of elements in the range (image). Mappings are also called *correspondences* [1]. Consider the mappings from set  $A$  to set  $B$  illustrated in Figure 5.1, where  $a$  are the elements of set  $A$  and  $b$  are the elements of set  $B$ . The mapping, which can be represented algebraically as a linear transformation, can be one of the following three types: injective; surjective; or bijective.

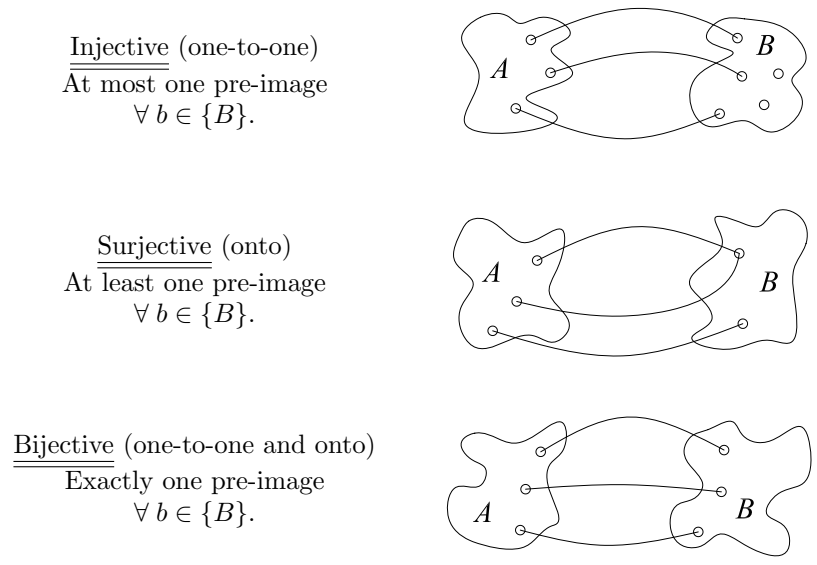

Figure 4.1: Injective, surjective, and bijective mappings.

Suppose both sets  $A$  and  $B$  contain the integers,  $\mathbb{Z}$ . An example of an injective mapping from  $A$  to  $B$  is the integers in  $A$  multiplied by 2:  $\mathbb{Z} * 2$ . The inverse of the mapping takes elements of set  $B$  and maps them to set  $A$ . The inverse mapping is  $\mathbb{Z}/2$ . Set  $B$  also contains all of the integers, but any odd integer divided by 2 is a rational number  $\mathbb{Q}$ , not an integer  $\mathbb{Z}$ . Hence, the odd  $b \in \{B\}$  have no pre-image, while all the even  $b$  have exactly one. Now, let sets  $A$  and  $B$  contain the rational and irrational numbers, sets  $\mathbb{Q}$  and  $\mathbb{I}$  respectively. A surjective mapping is the numbers in  $A$  squared:  $\{\mathbb{Q}, \mathbb{I}\}^2$ . The inverse maps an element of  $B$  as  $\pm\sqrt{b}$ . So, many numbers in  $B$  have two pre-images, but all have at least one. An example of a bijective mapping is the set of integers  $+1$ :  $\mathbb{Z} + 1$ . Clearly the inverse map  $\mathbb{Z} - 1$  is both one-to-one and onto: there is exactly one pre-image in  $A$  for every element in  $B$ .

A rigid body displacement in Euclidean space,  $\mathbb{E}^3$ , can be described geometrically as an *isometry*. The following quote is from [2]:

“An isometry is a bijective linear mapping of  $\mathbb{E}^3$  onto itself which leaves the distance between every pair of distinct points, and the angle between every pair of distinct lines, and planes, invariant.”

Although there is a motion associated with an isometry, the isometry does *not* represent a motion: it is the correspondence between an initial and a final position of a set of points. A motion is a continuous series of infinitesimal displacements. Because an isometry maps collinear points into collinear points, it transforms lines into lines, and hence is a *collineation*. The invariance of distance also ensures that triangle vertices are transformed into congruent triangle vertices. Thus, isometries preserve angle and are, therefore, also conformal transformations.

The word *set* so far has been used to mean a collection for geometric and algebraic objects. It may, however, be used more broadly to mean a collection of any sort. The set of isometries includes the following transformations: rotation; translation; screw; reflection (in a plane); central inversion (reflection in a point). It is easy to show that the set of isometries, together with a binary operator that combines any two of them, called *product*, defined on the set, constitutes a group,  $G$ . The elements of  $G$ ,  $\{x, y, z, \dots\}$  and the product operator must satisfy all the properties listed in Table (2.1) in order to constitute a group. Note that commutativity is, in general, not a group property.

Table 5.1: Group properties.

i	Closure	$(x * y) \in G$	$\forall (x, y) \in G$
ii	Associativity	$(x * y) * z = x * (y * z)$	$\forall (x, y, z) \in G$
iii	Identity	$\exists I \in G$	$I * x = x * I = x, \forall x \in G$
iv	Inverse	$\exists x^{-1} \in G$	$x * x^{-1} = x^{-1} * x = I, \forall x \in G$

The isometry group of the Euclidean plane  $\mathbb{E}^2$  is a sub-group of the isometry group of  $\mathbb{E}^3$ . Every isometry is the product of, at most, four reflections. In  $\mathbb{E}^2$ , four is replaced by three. Since a reflection reverses sense, an isometry is *direct* or *opposite* according to whether it is the product of an even or odd number of reflections. The set of direct isometries form a sub-group. This is because any product of direct isometries is another direct isometry. Whereas, the same does not hold for opposite isometries: the product of two opposite isometries is a direct isometry, violating the closure property. Hence, the opposite isometries are not a sub-group. The sub-group of direct isometries is also known as the group of *Euclidean displacements*,  $G_6$ . The sub-script 6 refers to the fact that 6 generalized coordinates are required to specify a displacement. This sub-group is also called the *special Euclidean 3D group*,  $SE(3)$ . In turn, the isometries are a sub-group of the *Euclidean similarity transformation group*, the principal group  $G_7$ . Seven parameters determine a similarity transformation, the additional one being a magnification factor to uniformly scale distances. The  $G_7$  transformations are conformal collineations, but the distance between two points is not, in general, invariant.

## 5.2 Isometry in the Euclidean Plane

An isometry in  $\mathbb{E}^2$  is a bijective mapping of the plane onto itself which preserves distance, and can be represented algebraically by a congruent linear transformation. There are four isometries in the plane.

### 5.2.1 Reflection $R$ in line $r$

Let  $r$  be any line in  $\mathbb{E}^2$ . A reflection in  $r$  leaves all points on  $r$  invariant, every other point of  $\mathbb{E}^2$  goes into the symmetrical point on a line right bisected by  $r$ . The reflection  $R$  in line  $r$  reverses the order of the triangle  $ABC$ . That is, the clockwise circulation of vertices  $ABC$  is transformed to a counter-clockwise (CCW) circulation  $A'B'C'$ , see Figure 5.2. The sense of the angles between edges,  $AC$  and  $AB$  for instance, are reversed. Hence, reflections are opposite isometries.

It is easy to show that a reflection in an arbitrary line  $r$ , called a *mirror line*, has the equations:

$$\begin{aligned}x' &= x \cos(2\varphi) + y \sin(2\varphi) + 2p \cos(\vartheta), \\y' &= x \sin(2\varphi) - y \cos(2\varphi) + 2p \sin(\vartheta),\end{aligned}$$

where  $\varphi$  is the angle  $r$  makes with the x-axis, CCW being positive,  $p$  is the perpendicular distance from the origin of the referenced coordinate system to the mirror line  $r$ ,  $\vartheta$  is the angle of the vector represented by this directed perpendicular connecting line segment, CCW being positive.

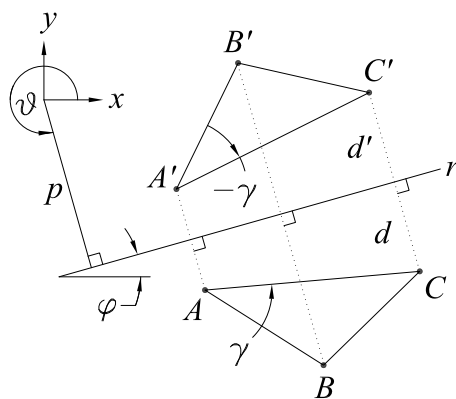
Figure 5.2: A reflection  $R$  in line  $r$ .

### 5.2.2 Rotation $S_\vartheta$ About Centre $S$ Through Angle $\vartheta$

Let  $S$  be any point in  $\mathbb{E}^2$ , and  $\vartheta$  be any measure of angle (CCW being positive). A rotation in  $S$  through  $\vartheta$  maps  $S$  onto itself, and any other point  $P$  onto  $P'$  such that distance  $SP = SP'$  and  $\angle PSP' = \vartheta$ , see Figure 5.3. The rotation about point  $S$  through angle  $\vartheta$  preserves distance, angle, and sense. That is, vertices of triangle  $ABC$  are mapped to  $A'B'C'$ . The order of the vertices is preserved as well as the sense of the angles between the edges. Hence, rotations are *direct*, or *positive* isometries.

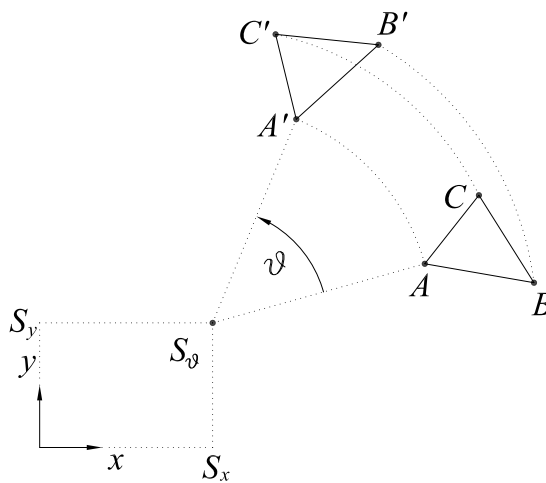
Figure 5.3: Rotation  $S_\vartheta$ .

An arbitrary rotation about any finite point has the following equations:

$$x' = x \cos \vartheta - y \sin \vartheta + S_x,$$

$$y' = x \sin \vartheta + y \cos \vartheta + S_y,$$

where  $S_x, S_y$  are the  $(x, y)$  coordinates of rotation centre  $S$ .

### 5.2.3 Translation $\tau$

Let  $\tau$  be a directed line-segment. A translation  $\tau$  maps any point  $P$  onto  $P'$  in the direction of  $\tau$  a distance equal to the length of  $\tau$ . The translation has no finite invariant points. All points of  $\mathbb{E}^2$  have different images under  $\tau$ . Moreover, translations are clearly direct isometries. They preserve distance, angle, sense, and orientation.

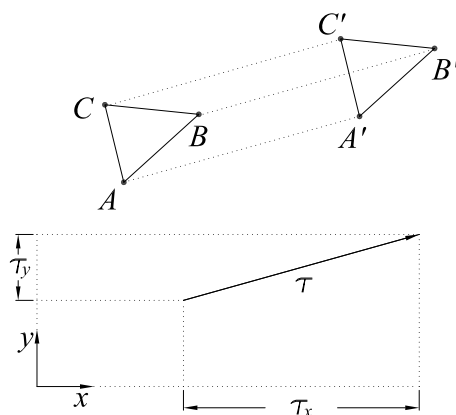

Figure 5.4: Translation  $\tau$ .

An arbitrary translation in  $\mathbb{E}^2$  has the following linear equations:

$$\begin{aligned} x' &= x + \tau_x, \\ y' &= y + \tau_y, \end{aligned}$$

where  $\tau_x$  and  $\tau_y$  are the directed length of  $\tau$  projected on the  $x$  and  $y$  axis, respectively.

### 5.2.4 Glide-Reflection $G$

A glide-reflection  $G$  is an opposite isometry that has no invariant point, but has a unique fixed line, called *the axis of  $G$* . The glide-reflection can be represented as the unique product of a translation and parallel reflection, see Figure 5.5.

Note that the product represented by  $\tau R$  implies the product operator symbol  $*$ , which simplifies the representation of the associated algebraic equations, thus

$$G = \tau * R = \tau R.$$

$G$  is represented by a half arrow the length of  $\tau$  along the mirror line  $r$

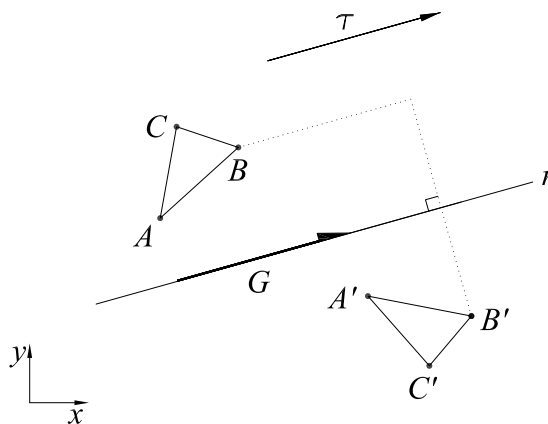
Figure 5.5: Glide-reflection  $G = \tau R$ .

### 5.3 Every Isometry in $\mathbb{E}^2$ is the Product of At Most Three Reflections

Every isometry can be represented, in many ways, as the products of different isometries. For the glide-reflection this is self-evident by definition. The reflection may be considered as the fundamental isometry as all isometries in  $\mathbb{E}^2$  may be represented by the product of, at most, three reflections. In  $\mathbb{E}^3$  replace *three* with *four*.

Before proceeding, recall the group properties of isometries:

**Closure** Let us simply accept that the product of any two isometries results in another isometry.

**Associativity** Consider three isometries  $A$ ,  $B$ , and  $C$ .

$$(AB)C = A(BC).$$

Proof:

$$\begin{aligned} (AB)C &= (A)(B)(C), \\ &= (A)BC, \\ &= A(BC). \end{aligned}$$

**Identity** Let the isometry  $I$  be the one resulting in the following:

$$x = x,$$

$$y = y.$$

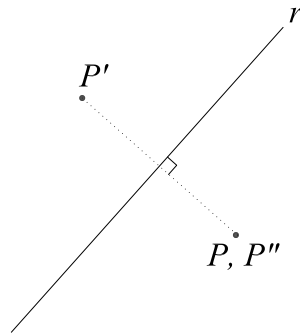
Figure 5.6:  $RR = I$ , the identity.

The identity leaves all points in  $\mathbb{E}^2$  invariant. The identity can be constructed as the product of two successive reflections in the same line. The first application of  $R$  maps  $P$  to  $P'$ . The second application maps  $P'$  to  $P''$ , which is  $P$  itself, see Figure 5.6.

**Inverse** Clearly, if an isometry can be “done”, it can always be “undone”. The inverse is indicated with a  $-1$  right superscript:  $S^{-1}$ . This leads directly to the result:

$$SS^{-1} = S^{-1}S = I.$$

Care must be taken when inverting a product. Consider two isometries  $R$  and  $S$ . Inverting the product  $RS$  is

$$(RS)^{-1} = S^{-1}R^{-1} \neq R^{-1}S^{-1}.$$

This becomes clear if we consider  $R$  and  $S$  as the operations of putting on socks and shoes. [2]

One commutative sub-group of isometries are the product of an isometry with its inverse. The product is otherwise, in general, not commutative, although a commutative sub-group containing only the translations does exist, and is discussed in Section 5.6.1. Consider the situation in Figure 5.7. Evidently, a translation results when  $R_1$  and  $R_2$  are parallel, but concatenation in different order produces different translations. Displacements produced by planar mechanisms *must* be direct, not opposite, isometries. Opposite isometries reverse sense, implying that the associated motion required the mechanism to leave the plane. Since this violates the planar condition, we need only consider the direct isometries for planar mechanisms.

We now consider the following product theorems for the products of two reflections:

**Theorem:** The product of two reflections in parallel lines is a translation in a direction perpendicular to the lines, and whose magnitude is twice the distance between the mirror lines.

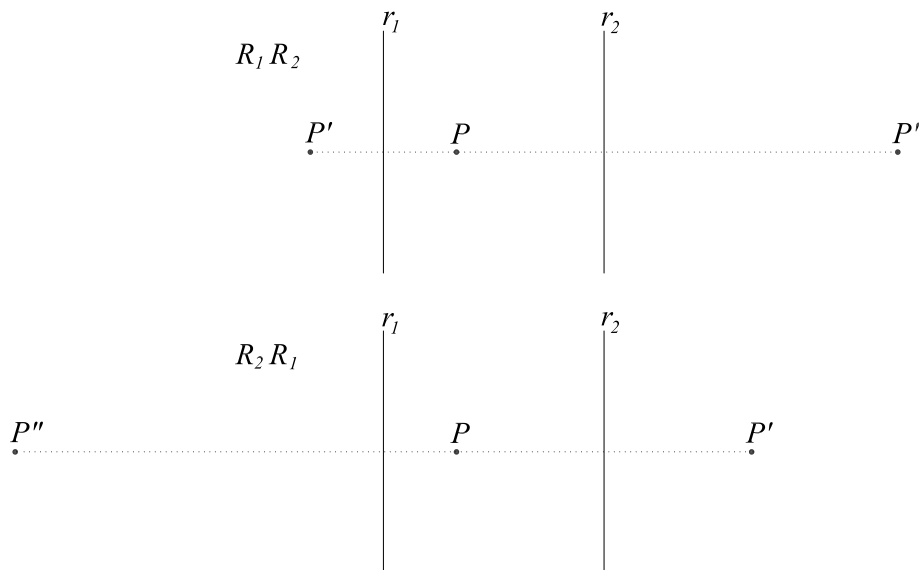

Figure 5.7: Product of two parallel reflections.

**Proof:** The product  $R_1 R_2$  operates on all points in the plane, including the mirror lines. The magnitude must be the same for all points. The points on  $r_1$  stay on  $r_1$  under  $R_1$ , but are reflected in  $r_2$  on lines right bisected by  $r_2$ . The magnitude is clearly twice the distance between  $r_1$  and  $r_2$ . Consider  $R_1 R_2$  in Figure 5.8. Note: The mirror lines are *not* unique!!! The product of two reflections in any two lines parallel to  $r_1$  and  $r_2$  separated by distance  $d$  will yield  $\tau$ .

**Theorem:** The product of two reflections in two finitely intersecting lines is a rotation about the point of intersection through twice the angle between the mirror lines, see Figure 5.9.

**Proof:** Clearly,  $SP = SP' = SP''$ . The angle between  $SP$  and  $SP''$  is:

$$2(\alpha + \beta) = 2\varphi = \vartheta$$

Note: The same rotation results for every pair of mirror lines through the same point with angle  $\varphi$  between them.

## 5.4 Products of Three Reflections

While not important for planar mechanisms, the following theorems are important for spacial mechanisms in particular, and for spatial kinematics in general. There are four distinct ways to arrange three lines in the plane. Or course in all cases, the product of three reflections must be another opposite isometry.

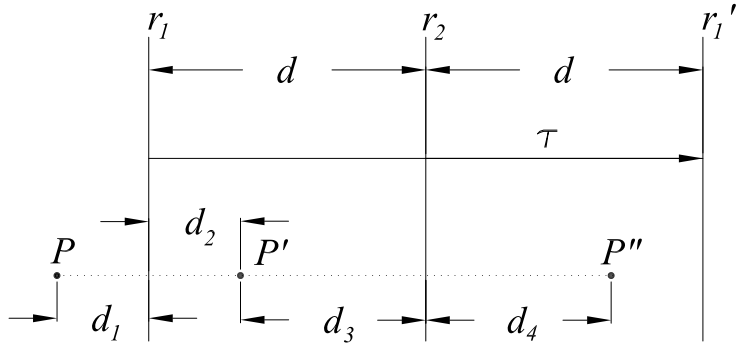

Figure 5.8: Product of parallel reflections.

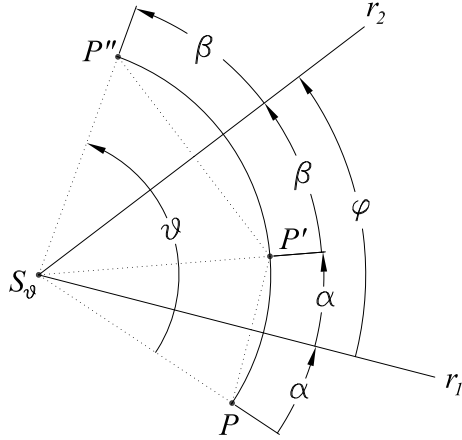

Figure 5.9: Product of two intersecting reflections.

**5.4.1 Case 1: All three mirror lines intersect in one point**

**Theorem:** The product of three such reflections  $R_1R_2R_3$  is a single reflection  $R$ , see Figure 5.10.

**Proof:** Select  $r$  such that  $\angle r_2r_3 = \angle r_1r$ . This condition means  $R_2R_3 = R_1R$ . Then  $R_1(R_2R_3) = R_1(R_1R) = IR = R$ .

**5.4.2 Case 2: All three mirror lines are parallel**

**Theorem:** The product of three reflections  $R_1, R_2, R_3$  whose mirror lines are all parallel is a single reflection,  $R$ , parallel to the given three.

**Proof:** Select  $r$ , as in Figure 5.11, to be parallel to  $r_3$  such that the directed distance from  $r$  to  $r_3$  is identical to the directed distance from  $R_1$  to  $r_2$ ,

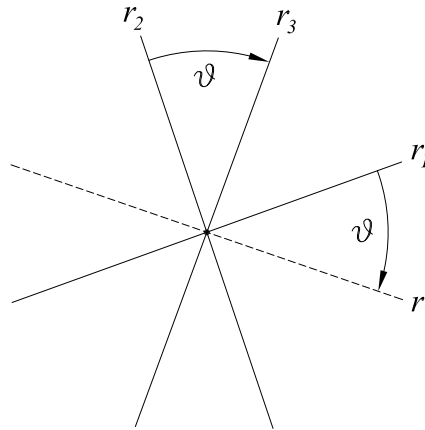

Figure 5.10: Three reflections intersecting in one point.

giving:

$$\begin{aligned}
 R_1 R_2 &= R R_3, \\
 \Rightarrow (R_1 R_2) R_3 &= (R R_3) R_3, \\
 &= R I, \\
 &= R.
 \end{aligned}
 \tag{5.1}$$

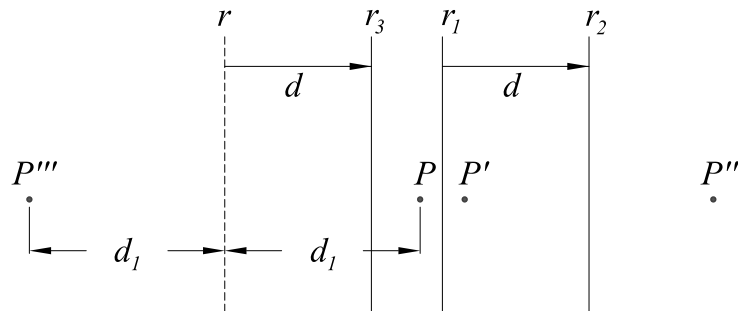

Figure 5.11: Three reflections with parallel mirror lines.

### 5.4.3 Case 3: Three reflections whose mirror lines intersect in three distinct points

Before progressing to the theorem we must discuss two special products:

1. The product of two reflections intersecting in perpendicular mirror lines is a rotation through 180 degrees, called a half-turn,  $H = R_1 \perp R_2$ .
2. The product of a reflection and a half turn whose centre is not on the mirror line is a glide reflection.

The proof of 1 follows from definition. The proof of 2 uses the fact that a glide is the product of a translation and a reflection in a line parallel to the direction of the translation, and a translation is the product of two parallel reflections, see Figure 5.12.

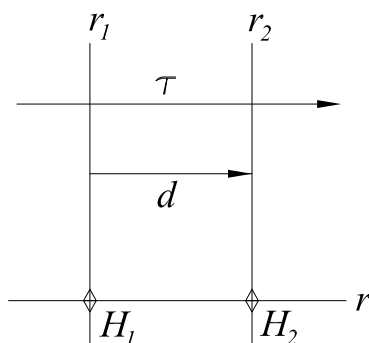

Figure 5.12: Glide-Reflection.

A rotation of 180 degrees about centre  $H$  can be represented in infinitely many ways as the product of two reflections whose mirror lines intersect at  $H$  and are mutually orthogonal. Now consider half-turn  $H$  and reflection  $R$  whose mirror line does not pass through  $H$ . Decompose  $H$  into the product of  $R_1 R_2$  where  $r_2$  is parallel to  $r$  and  $r_1$  is perpendicular to  $r$ . Now  $HR = R_1 R_2 R = R_1 \tau = G$ . See Figures 5.13 and 5.14.

**Theorem** The product of three reflections  $R_1 R_2 R_3$  whose three mirror lines  $r_1, r_2, r_3$  intersect in three distinct finite points is a glide-reflection.

**Proof** Select  $r_4$  and  $r_5$  such that  $r_4 \perp r_1$  and  $\angle r_2 r_3 = \angle r_4 r_5$  and  $r_4$  and  $r_5$  are incident on the intersection of  $r_2$  and  $r_3$ ,  $S$ . See Figure 5.15.

$$\begin{aligned}
 R_1 R_2 R_3 &= R_1 R_4 R_5 \text{ since } R_1 \perp R_4, \\
 &= H R_5 \text{ since } R_1 R_4, \\
 &= R_7 \tau_{(2d)}, \\
 &= G.
 \end{aligned}$$

The three reflections are equivalent to the glide-reflection, which is also equivalent to the product of  $H R_5$ , which can be decomposed into  $R_7 R_6 R_5$

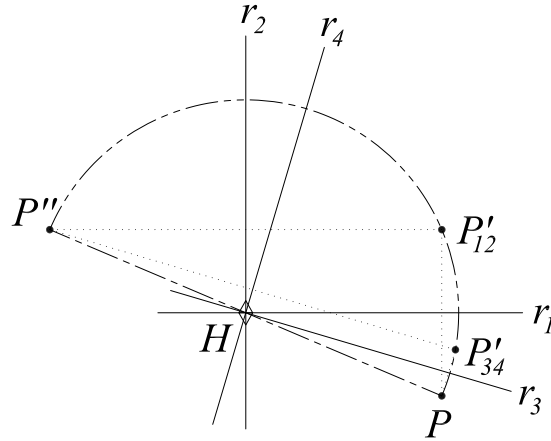

Figure 5.13: Rotations can be represented as the product of *any* two mirror lines intersecting on the rotation centre separated by half the rotation angle. The half-turn is no different.

such that (see Figure 5.16):

$$\begin{aligned}
 G &= HR_5, \\
 &= R_7R_6R_5, \\
 &= R_7\tau_{(2d)}, \\
 &= G, \\
 &= R_1R_2R_3.
 \end{aligned}$$

#### 5.4.4 Case 4: Three reflections with two parallel mirrors

**Theorem:** The product of three reflections where only two mirror lines are parallel is a single glide-reflection.

**Proof:** Referring to see Figure 5.17, we can introduce  $R_4$  and  $R_5$  such that the angle from  $r_4$  to  $r_5$  is  $\vartheta$  with  $r_5$  orthogonal to  $r_1$  and  $r_3$ , the two parallel mirrors.

$$\begin{aligned}
 R_1R_2 &= S_{2\vartheta} \\
 &= R_4R_5 \\
 \Rightarrow R_1R_2R_3 &= R_4R_5R_3 \\
 &= R_4H \\
 &= G.
 \end{aligned}$$

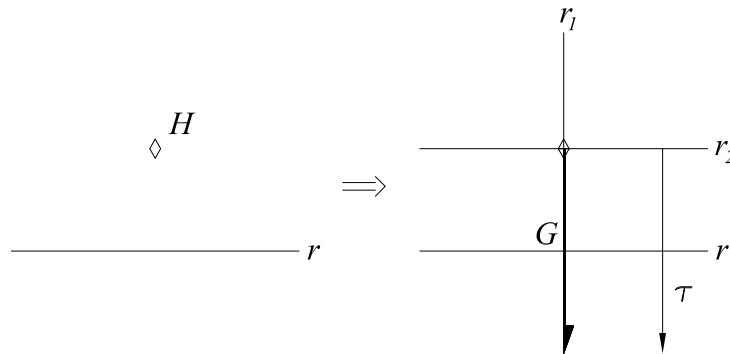

Figure 5.14: Product of half-turns and non-incident reflections are glide reflections.

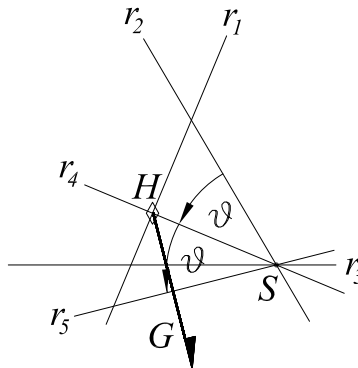

Figure 5.15: Three reflections whose mirror lines intersect in three distinct finite points are a glide-reflection.

Furthermore, referring to Figure 5.18, the resulting glide reflection can be decomposed into the product  $R_4R_6R_7$ :

$$G = R_4R_6R_7 = \tau_{2d}R_7.$$

### 5.4.5 Summary

Any isometry in  $\mathbb{E}^2$  is, or can always be expressed as the product of, at most, three reflections. For a summary, see Figure 5.19.

Figure 5.16: The product of  $HR_5$ .

Figure 5.17: Three reflections with only two parallel mirror lines is a glide-reflection.

## 5.5 The Pole of a Planar Displacement

The group of planar displacements in  $\mathbb{E}^2$  are the sub-group of the direct isometries in  $\mathbb{E}^2$ . An important theorem, which we will use later on with kinematic mapping, is that any general planar displacement can always be represented by a single rotation. Even a pure translation may, if we bound  $\mathbb{E}^2$  with the line at infinity,  $L_\infty$  (thereby creating the projective plane  $P_2$ ), be considered a rotation through an infinitesimal angle about the point of intersection between  $L_\infty$  and the normal to the direction of translation. The coordinates of this rotation centre are invariant under the rotation. This unique point is the *pole* of the displacement.

Before pursuing this topic, we must carefully discuss two different interpretations of a displacement. One is a *vector transformation* where displacements transform point position vectors. The other is a *coordinate transformation* (which we will use almost exclusively). Here, the position vector is unmoving, but the bases change relative to it.

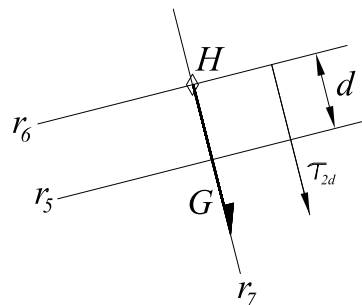
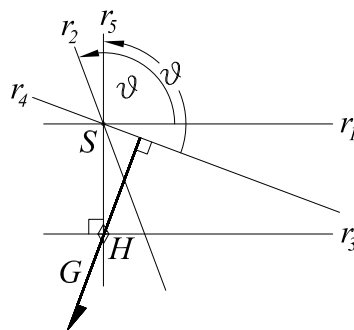
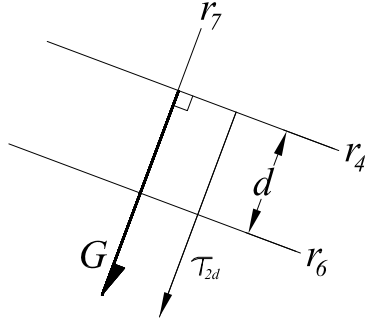

Figure 5.18: Equivalence to three reflections in two parallel mirrors.

### 5.5.1 Vector Transformation

The vector  $\mathbf{v}'$  is the image of vector  $\mathbf{v}$  under a CCW rotation through angle  $\vartheta$ , centred at the origin, see Figure 5.20. Given  $(x, y)$  and  $\vartheta$ , what are  $(x', y')$ ?

$$x = |\mathbf{v}| \cos \varphi, \quad y = |\mathbf{v}| \sin \varphi \\ x' = |\mathbf{v}'| \cos(\varphi + \vartheta), \quad y' = |\mathbf{v}'| \sin(\varphi + \vartheta).$$

We use the fact that  $|\mathbf{v}| = |\mathbf{v}'|$ , and the trigonometric identities:

$$\cos(\varphi + \vartheta) = \cos \varphi \cos \vartheta - \sin \varphi \sin \vartheta, \\ \sin(\varphi + \vartheta) = \cos \varphi \sin \vartheta + \sin \varphi \cos \vartheta,$$

which gives:

$$x' = |\mathbf{v}'| [\cos \varphi \cos \vartheta - \sin \varphi \sin \vartheta], \\ y' = |\mathbf{v}'| [\cos \varphi \sin \vartheta + \sin \varphi \cos \vartheta].$$

Now, using:

$$x = |\mathbf{v}| \cos \varphi \Rightarrow |\mathbf{v}'| = x / \cos \varphi, \\ y = |\mathbf{v}| \sin \varphi \Rightarrow |\mathbf{v}'| = y / \sin \varphi,$$

yields:

$$x' = |\mathbf{v}'| \cos \varphi \cos \vartheta - |\mathbf{v}'| \sin \varphi \sin \vartheta = x \cos \vartheta - y \sin \vartheta, \\ y' = |\mathbf{v}'| \cos \varphi \sin \vartheta + |\mathbf{v}'| \sin \varphi \cos \vartheta = x \sin \vartheta + y \cos \vartheta.$$

Assembling in matrix form yields the general vector transformation for rotation:

$$\begin{bmatrix} x' \\ y' \end{bmatrix} = \begin{bmatrix} \cos \vartheta & -\sin \vartheta \\ \sin \vartheta & \cos \vartheta \end{bmatrix} \begin{bmatrix} x \\ y \end{bmatrix}. \quad (5.2)$$

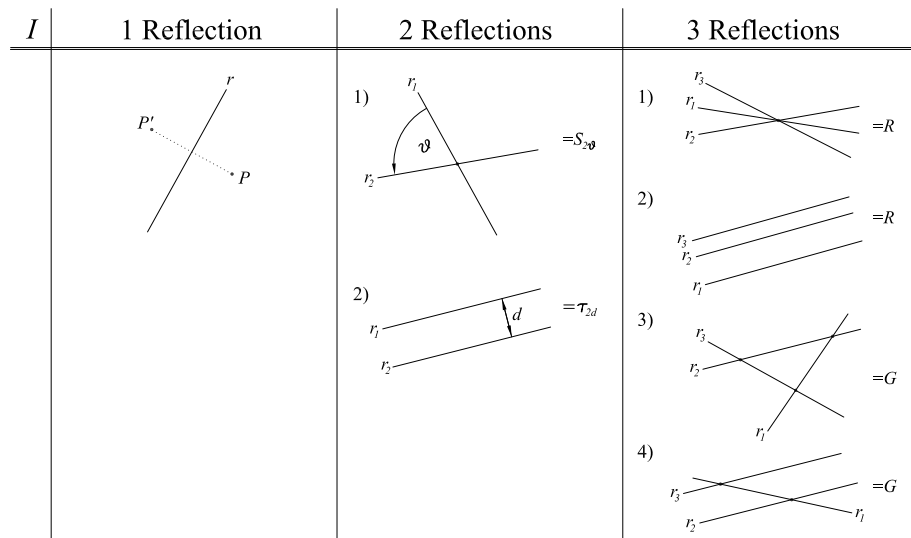

Figure 5.19: Summary of Isometries.

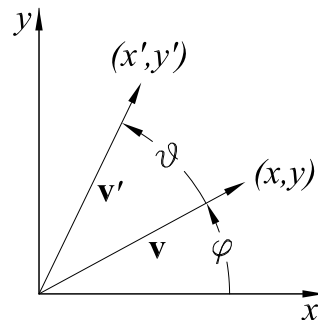

Figure 5.20: Vector transformation.

### 5.5.2 Coordinate Transformation

Given  $(x, y)$  and  $\vartheta$ , what are  $(x', y')$ , the coordinates of the same point in the transformed coordinate system?

Referring to Figure 5.21, by inspection, we have:

$$\begin{aligned} P_{x'} &= P_x \cos \vartheta + P_y \sin \vartheta, \\ P_{y'} &= P_y \cos \vartheta - P_x \sin \vartheta. \end{aligned}$$

Assembling in matrix form:

$$\begin{bmatrix} x' \\ y' \end{bmatrix} = \begin{bmatrix} \cos \vartheta & \sin \vartheta \\ -\sin \vartheta & \cos \vartheta \end{bmatrix} \begin{bmatrix} x \\ y \end{bmatrix}, \tag{5.3}$$

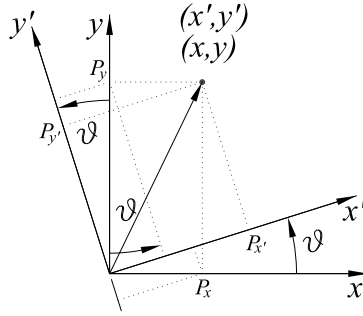

Figure 5.21: Coordinate transformation.

It is clear the rotation matrices in Equations (5.2) and (5.3) are each other's inverse. Hence, the interpretations are also inverse.

In kinematics we usually know the coordinates of points in the transformed frame and need to know their coordinates in the original frame. For the rotation matrix in Equation (5.3), this is simply the inverse:

$$\begin{bmatrix} x \\ y \end{bmatrix} = \begin{bmatrix} \cos \vartheta & -\sin \vartheta \\ \sin \vartheta & \cos \vartheta \end{bmatrix} \begin{bmatrix} x' \\ y' \end{bmatrix}. \quad (5.4)$$

### 5.5.3 General Planar Displacements

It is convenient to consider a general displacement of a rigid body in  $\mathbb{E}^2$  as the displacement of a reference coordinate system  $E$  that moves with the rigid body relative to a fixed reference frame  $\Sigma$ . Moreover, let the coordinates of points in  $E$  be described by the lowercase pairs  $(x, y)$  and those in  $\Sigma$  by the uppercase pairs  $(X, Y)$ . A general displacement of  $E$  relative to  $\Sigma$  is described by three numbers  $(a, b, \varphi)$ , where  $(a, b)$  are the coordinates of  $O_E$  (the origin of  $E$ ) expressed in  $\Sigma$ , and  $\varphi$  is the angle the x-axis makes with respect to the X-axis, with CCW rotations considered as positive. The position of a point in  $E$  described in  $\Sigma$  can be given by:

$$\begin{bmatrix} X' \\ Y' \end{bmatrix} = \begin{bmatrix} \cos \varphi & -\sin \varphi \\ \sin \varphi & \cos \varphi \end{bmatrix} \begin{bmatrix} x' \\ y' \end{bmatrix} + \begin{bmatrix} a \\ b \end{bmatrix}. \quad (5.5)$$

Equation (5.5) is *not* a linear transformation because the translation of the sum of two vectors  $\mathbf{x}$  and  $\mathbf{y}$  by the amount  $\mathbf{d}$  is  $\mathbf{x} + \mathbf{y} + \mathbf{d}$ , and not the sum of the translation of each vector separately, which is  $(\mathbf{x} + \mathbf{d}) + (\mathbf{y} + \mathbf{d}) = \mathbf{x} + \mathbf{y} + 2\mathbf{d}$ . This violates the definition of a linear transformation.

If  $T : V \rightarrow W$  is a function from the vector space  $V$  to the vector space  $W$ , then  $T$  is a linear transformation iff:

1.  $T(\mathbf{u} + \mathbf{v}) = T(\mathbf{u}) + T(\mathbf{v})$ ,  $\forall \mathbf{u}$  and  $\mathbf{v} \in V$ ;
2.  $T(k\mathbf{u}) = T k(\mathbf{u})$   $\forall \mathbf{u} \in V$  and all scalars.

Clearly, Equation (5.5) violates condition 1. Moreover it is not a linear transformation because Equation (5.5) cannot be represented by an  $n \times n$  matrix. This situation can be remedied by the use of *homogenous coordinates*. They will be discussed in detail later, but we can start using them now. They replace cartesian coordinate pairs  $(x, y)$  with triples of ratios  $(x : y : z)$  such that:

$$\begin{aligned} x' &= \frac{x}{z}, & y' &= \frac{y}{z}, \\ X' &= \frac{X}{Z}, & Y' &= \frac{Y}{Z}. \end{aligned}$$

Substituting these into Equation (5.5) gives:

$$\begin{aligned} \frac{X}{Z} &= \frac{x}{z} \cos \varphi - \frac{y}{z} \sin \varphi + a, \\ \frac{Y}{Z} &= \frac{x}{z} \sin \varphi + \frac{y}{z} \cos \varphi + b. \end{aligned} \quad (5.6)$$

The third coordinate,  $Z$  and  $z$  may be thought of simply as scaling factors. As long as  $Z \neq 0$  and  $z \neq 0$  we can set  $Z = z$ , multiply Equations (5.6) through by  $Z$  and write Equation (5.5) as a linear transformation, which is computationally extremely convenient:

$$\begin{bmatrix} X \\ Y \\ Z \end{bmatrix} = \begin{bmatrix} \cos \varphi & -\sin \varphi & a \\ \sin \varphi & \cos \varphi & b \\ 0 & 0 & 1 \end{bmatrix} \begin{bmatrix} x \\ y \\ z \end{bmatrix}. \quad (5.7)$$

Equation (5.7) represents a displacement of reference frame  $E$  with respect to  $\Sigma$ , see Figure 5.22. Displacements of  $E$  relative to  $\Sigma$  are completely described by the three numbers  $a, b, \varphi$  where:

- $(x : y : z)$  are the homogenous coordinates of points in  $E$ ;
- $(X : Y : Z)$  are the homogenous coordinates of the same point in  $\Sigma$ ;
- $(a, b)$  are the cartesian coordinates of the origin of  $E, O_E$  measured in  $\Sigma$ , i.e. the position vector of  $O_E$  in  $\Sigma$ ;
- $\varphi$  is the rotation angle measured CCW from the X-axis towards the x-axis, (CCW being considered positive).

The pole of a planar displacement is defined as the coordinates of the unique invariant point, which is the eigenvector corresponding to the one real eigenvalue of the matrix in Equation (5.7). Eigenvalues represent matrix invariants and are roots of the characteristic equation:

$$\begin{aligned} \lambda \mathbf{x} &= \mathbf{A} \mathbf{x}, \\ (\mathbf{A} - \lambda \mathbf{I}) \mathbf{x} &= 0. \end{aligned} \quad (5.8)$$



Figure 5.22: A general displacement of  $E$  with respect to  $\Sigma$  in terms of  $a$ ,  $b$ ,  $\varphi$ .

With  $\lambda$  being the scalar leading to non-trivial solutions of Equation (5.8). Non-trivial solutions exist if, and only if

$$\det(\mathbf{A} - \lambda\mathbf{I}) = 0.$$

For Equation (5.7) the characteristic polynomial is third order and factors to:

$$(1 - \lambda)(\lambda^2 - 2\lambda \cos \varphi + 1) = 0$$

The three eigenvalues are:

$$\begin{aligned} \lambda_1 &= 1, \\ \lambda_2 &= e^{i\varphi}, \\ \lambda_3 &= e^{-i\varphi}. \end{aligned}$$

The eigenvector associated with  $\lambda = 1$  is the pole of the displacement. We can compute it by setting  $Z = z = 1$  and expanding Equation (5.7), revealing two equations in two unknowns: the pole coordinates. From

$$\begin{bmatrix} x_p \\ y_p \\ 1 \end{bmatrix} = \begin{bmatrix} \cos \varphi & -\sin \varphi & a \\ \sin \varphi & \cos \varphi & b \\ 0 & 0 & 1 \end{bmatrix} \begin{bmatrix} x_p \\ y_p \\ 1 \end{bmatrix},$$

we get

$$\begin{aligned} x_p - x_p \cos \varphi + y_p \sin \varphi - a &= 0, \\ y_p - x_p \sin \varphi - y_p \cos \varphi - b &= 0. \end{aligned} \quad (5.9)$$

Solving using Cramer's rule, we obtain

$$\begin{aligned} x_p &= \frac{1}{2} \left( \frac{a \sin \varphi - b(1 + \cos \varphi)}{\sin \varphi} \right), \\ y_p &= \frac{1}{2} \left( \frac{a(1 + \cos \varphi) + b \sin \varphi}{\sin \varphi} \right). \end{aligned} \quad (5.10)$$

A much more symmetric, and as it turns out useful, representation of the pole coordinates are obtained if we use the half-angle substitutions in Equations (5.10):

$$\begin{aligned}\sin \varphi &= 2 \sin(\varphi/2) \cos(\varphi/2), \\ \cos \varphi &= \cos^2(\varphi/2) - \sin^2(\varphi/2),\end{aligned}$$

which gives

$$\begin{aligned}x_p &= \frac{a \sin(\varphi/2) - b \cos(\varphi/2)}{2 \sin(\varphi/2)}, \\ y_p &= \frac{a \cos(\varphi/2) + b \sin(\varphi/2)}{2 \sin(\varphi/2)}.\end{aligned}\tag{5.11}$$

The value of the homogenizing coordinate, which we choose to be  $Z = z$ , is arbitrary and we are free to set it to be  $2 \sin(\varphi/2)$ , which gives us the homogenous coordinates of the pole (for now we ignore rotations of  $\varphi = 180$  degrees).

$$\begin{aligned}X_p = x_p &= a \sin(\varphi/2) - b \cos(\varphi/2), \\ Y_p = y_p &= a \cos(\varphi/2) + b \sin(\varphi/2), \\ Z_p = z_p &= 2 \sin(\varphi/2).\end{aligned}\tag{5.12}$$

The displacement which ends up translating  $O_E$  to  $a, b$  and rotating the x-axis by  $\varphi$  can be represented by a single rotation about point  $P$  by  $\varphi$  degrees, see Figure 5.23. The pole coordinates of a displacement are used in the kinematic

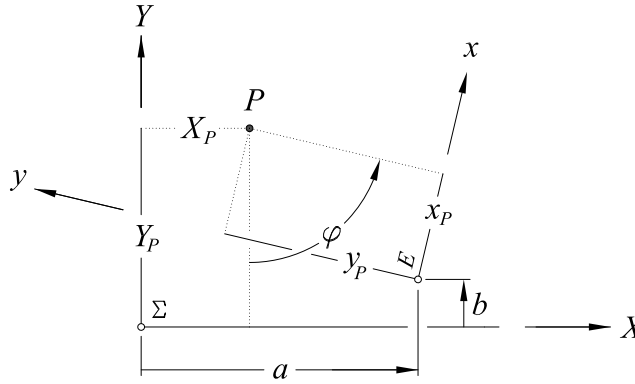

Figure 5.23: Pole of a displacement.

mapping we shall be working with. But there is much ground to cover between here and there.

## 5.6 Obtaining the Poles Geometrically

Obtaining the pole coordinates amounts to determining the products of the sub-group of direct isometries. This requires looking at the products of two translations, two rotations, and the product of a translation and rotation.

### 5.6.1 Products of Translations

Because a translation involves no change in orientation, the product of any number of sequential translations is a translation. Translations are represented by *free* vectors, i.e. no specific line of action, only direction and magnitude. Hence, they can always be arranged *tip-to-tail*, and the product of  $n$  translations is the vector joining the tail of  $\tau_1$  to the tip of  $\tau_n$ , see Figure 5.24. By observation, it is evident that the translations are a commutative sub-group of isometries. The product  $\tau$  is also a free vector: it is a directed line-segment that can be

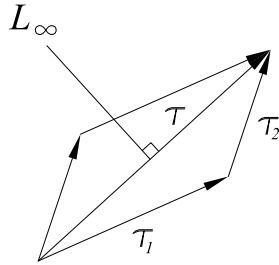

Figure 5.24: The product of two translations is always a translation.

placed anywhere in the plane. These line segments all point towards the same point on  $L_\infty$  (so, we are really talking about  $P_2$ , the projective plane... more on that later). Similarly, the pencil,  $\eta$ , of normals to  $\tau$  all intersect in another unique point on  $L_\infty$ , see Figure 5.25. The projective plane  $P_2$  is bounded by

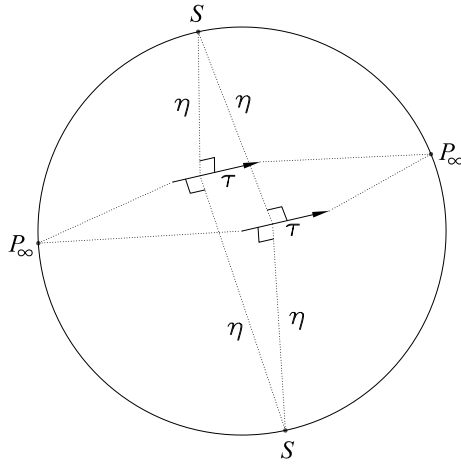

Figure 5.25: Model of the line at infinity,  $L_\infty$ .

a line that is infinitely distant. This line is the intersection of  $P_2$  and the plane at infinity,  $\pi_\infty$ , and hence must be a line. However, it is a line with some interesting properties. Two parallel lines, let's say the directions of the

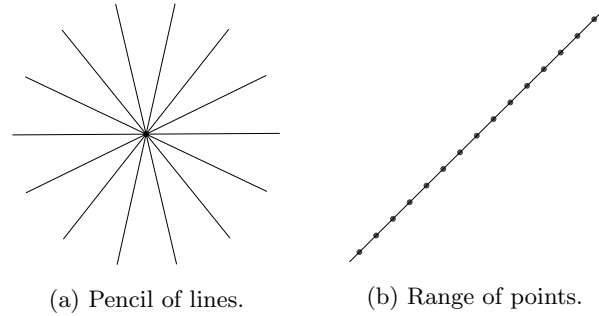

Figure 5.26: An infinity of lines on a point and its dual: an infinity of points on a line.

two parallel translations illustrated in Figure 5.25, intersect in one and only one point on  $L_\infty$ , called  $P_\infty$  in the figure, regardless of which direction that  $L_\infty$  is approached. So, for illustrative purposes only, the line at infinity is usually represented as a circle, though it is obtained by the intersection of two planes and hence must be a line and must be represented by a linear equation. This reveals what seems to be a paradox from the standpoint of Euclidean geometry: the projective plane  $P_2$  is infinite in extent, but it is also bounded by the line at infinity,  $L_\infty$ . This apparent paradox is resolved later on by examining the structure of projective geometry, which turns out to be embedded in the structure of all linear geometries.

With the above in mind, the product of two translations can be represented by a rotation about a unique centre  $S$  on  $L_\infty$  through an infinitesimally small angle. Thus, the pole of a translation is always a point on  $L_\infty$ .

### 5.6.2 Products of Rotations

Clearly, the product of any number of rotations about a single centre is a rotation about that same centre through the sum of the signed angles of the individual rotations. For two rotations with distinct centres, there are three cases to consider. Using these three cases, the product of any number of rotations about arbitrary centres can be determined. This product will always be a rotation, or a translation, with the exception of degenerate cases. Of course, in the projective geometric sense, the product is always a rotation.

**Case 1:** Same rotation angle, two distinct centres. This product will be written as  $A_\vartheta B_\vartheta$ . Recall, we can represent a rotation  $A_\vartheta$  in many ways by two intersecting mirror lines. Actually, they are a pencil of line pairs on the rotation centre separated by angle  $\vartheta/2$ , see Figure 5.26a.

To determine the pole and equivalent single rotation we make the following construction. Select  $r$  to contain both centres  $A$  and  $B$ . Then,  $A_\vartheta = R_1 R$  and  $B_\vartheta = R R_2$ . The product of the two rotations  $A$  and  $B$  is another

rotation,  $C_\varphi$ :

$$A_\varphi B_\varphi = R_1 R R R_2 = R_1 R_2 = C_\varphi.$$

Note: the two identical rotations, R, combine as the identity, I. The rotation angle is easy to obtain from a basic triangle theorem: the sum of the interior angles equals 180 degrees (or  $\pi$  radians), see Figure 5.27. Hence,

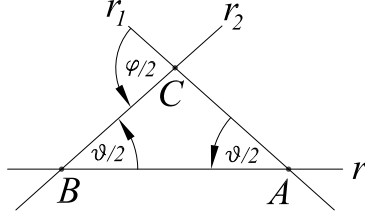

Figure 5.27: Two rotations  $A_\varphi B_\varphi$ , same angle, distinct centres.

we can write:

$$\begin{aligned} \frac{\vartheta}{2} + \frac{\vartheta}{2} + \left(180 - \frac{\varphi}{2}\right) &= 180 \\ \Rightarrow \varphi &= 2\vartheta. \end{aligned}$$

The rotation centre of  $C$  is the invariant point of the product of  $A_\varphi$  and  $B_\varphi$ .

**Case 2:** Same angle, but opposite sense, two distinct centres. We proceed as in Case 1. Referring to Figure 5.28, select  $r$  to contain both centres  $A$  and

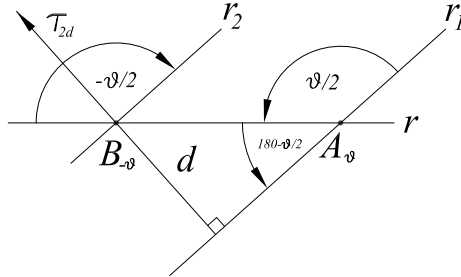

Figure 5.28: Two rotations with distinct centres and equal angles with opposite sense.

*B.* With this construction  $A_\varphi = R_1 R$  and  $B_{-\varphi} = R R_2$ , which yields

$$A_\varphi B_{-\varphi} = R_1 R R R_2 = R_1 R_2 = \tau.$$

Clearly, remaining mirror lines  $r_1$  and  $r_2$  are parallel because of this construction, and hence the isometry resulting from the product  $A_\varphi B_{-\varphi}$  is the translation  $\tau$ . The distance  $d$  is simply

$$d = |AB| \sin \left(180 - \frac{\vartheta}{2}\right).$$

But as discussed earlier, this translation in  $\mathbb{E}^2$  can be considered a rotation in  $P_2$ .

**Case 3** Two different angles and two distinct centres, see Figure 5.29. We

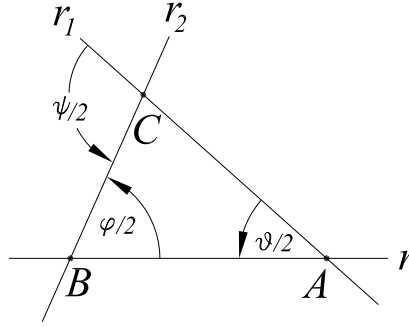

Figure 5.29: Two different rotation centres and angles.

proceed with the same construction as in Cases 1 and 2 by selecting  $r$  to contain both rotation centres  $A$  and  $B$ , yielding

$$A_{\vartheta}B_{\varphi} = R_1 R R R_2 = R_1 R_2 = C_{\psi}.$$

The angle  $\psi$  is obtained as:

$$\begin{aligned} \frac{\vartheta}{2} + \frac{\varphi}{2} + (180 - \frac{\psi}{2}) &= 180 \\ \Rightarrow \psi &= \vartheta + \varphi. \end{aligned}$$

The location of this rotation centre  $C$  can be determined for both Cases 1 and 3 using the Law of Sines, with triangle edge lengths and interior angles as defined in Figure 5.30.

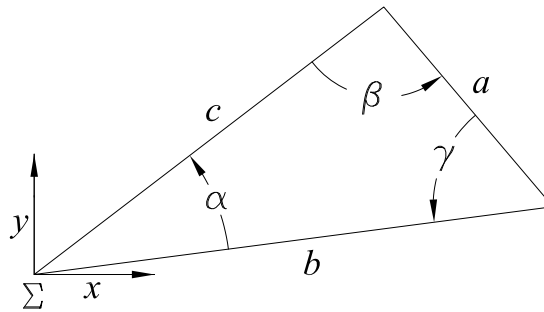

Figure 5.30: Law of sines.

$$\frac{\sin \alpha}{a} = \frac{\sin \beta}{b} = \frac{\sin \gamma}{c}$$

$$\Rightarrow c = \frac{\sin \gamma}{\sin \beta} b.$$

For the Case 3 triangle shown in Figure 5.29

$$|CB| = \frac{\sin(\vartheta/2)}{\sin(180 - \psi/2)} |AB|,$$

which gives the coordinates of  $C$  in reference frame  $\Sigma$ . We see immediately that the products of rotations are *not* a commutative sub-group.

### 5.6.3 Products of Translations and Rotations

Here we can have  $\tau S$  and  $S\tau$ , which are in general different displacements. Hence, these products are generally not commutative.

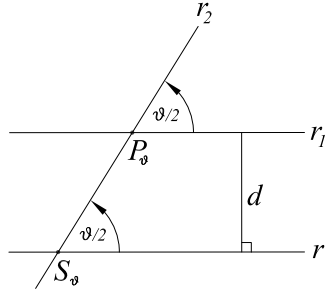

Figure 5.31: Product of translation and rotation.

**Translation followed by Rotation:**  $\tau S_\vartheta$ . We decompose the product as in Figure 5.31:

$$\tau S_\vartheta = R_1 R R R_2 = R_1 R_2 = P_\vartheta.$$

This product is a rotation through the same angle  $\vartheta$  but about a translated centre. The coordinates of  $P$  relative to  $S$  are simply the basis elements of the position vector of distance  $|SP|$  given by:

$$|SP| = \frac{d}{\sin(\vartheta/2)}$$

Rotation centre  $P$  is the pole of the product of displacements.

**Rotation followed by Translation:**  $S_\vartheta \tau$ . We take product of the same displacements, but in opposite order, as shown in Figure 5.32 and write:

$$S_\vartheta \tau = R_1 R R R_2 = R_1 R_2 = Q_\vartheta,$$

which is again a rotation, but about a different centre. Hence these products are not commutative, but still a sub-group of the group of planar isometries.

We can use these results to determine the pole coordinates for any arbitrary product of planar displacements.

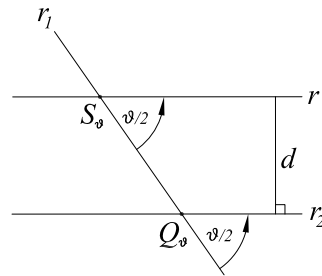

Figure 5.32: Product of a rotation and a translation.

## 5.7 Computing DOF Using Group Concepts

The relative motion associated with each of the lower kinematic pairs illustrated in Figure 5.33 constitute a sub-group of the group of Euclidean displacements  $G_6$  under the binary product operator (i.e. the composition of two displacements). In other words, the motions of all  $R$ -pairs are a sub-group of  $G_6$ , the motions of all  $E$ -pairs are a sub-group of  $G_6$ , etc.. The dimension of these sub-groups is defined to be the *degree of freedom* (DOF) of the relative motion permitted by the lower pair. The dimension is indicated by  $\dim(G_S)$ , where  $G_S \subset G_6$ . These sub-groups, together with their corresponding dimension are listed in Table 5.2.

Figure 5.33: The six lower pairs: (a)  $R$ , revolute; (b)  $P$ , prismatic; (c)  $H$ , helical; (d)  $C$ , cylindrical; (e)  $S$ , spherical; (f)  $E$ , planar.

Table 5.2: Lower Pair Sub-groups and Their Dimension

Lower Pair	$G_S$	$\dim(G_S)$
$E$	$\mathcal{E}$	3
$S$	$\mathcal{S}$	3
$C$	$\mathcal{C}$	2
$H$	$\mathcal{H}$	1
$P$	$\mathcal{P}$	1
$R$	$\mathcal{R}$	1

Let the product of two sub-groups indicated by

$$G' = G_1 * G_2$$

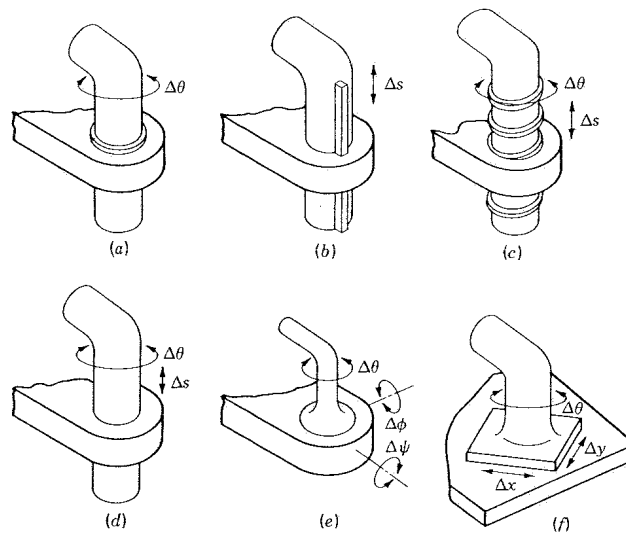
be the composition of the displacements they represent. Let  $\dim(G') = d$ . In the mathematical model which follows,  $d$  represents the maximum possible motion group dimension. In  $\mathbb{E}^3$   $d = 6$ ; in  $\mathbb{E}^2$ , the absolute maximum is  $d = 3$ . This is because in  $\mathbb{E}^2$  the origin of the moving reference frame  $E$  can translate independently in both the  $X$  and  $Y$  basis vector directions in  $\Sigma$  in any linear combination, and  $E$  can change it's orientation about any axis normal to the relatively fixed and moving coordinate systems. For example, consider the  $RPR$  linkage shown in Figure 5.34, which implies a serial chain of four links connected to ground by a sequence of revolute-prismatic-revolute joints. In  $\mathbb{E}^3$ ,  $d = 6$  because there are three linearly independent translation directions and three linearly independent rotations about basis vector directions. The  $i^{th}$  kinematic

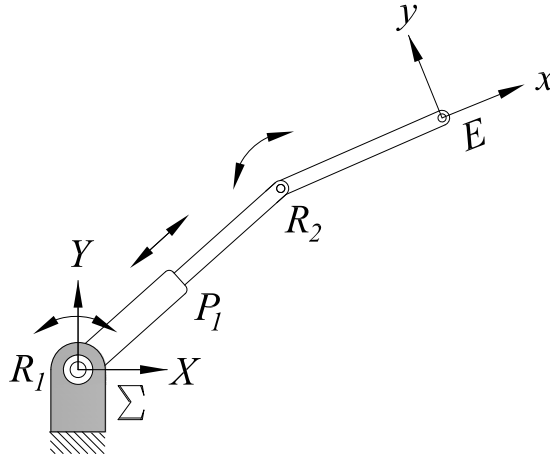

Figure 5.34: Reference frame  $E$  has 3 DOF relative to  $\Sigma \Rightarrow d = 3$ .

pair imposes  $\mu_i$  constraints on the two links it couples. For example, in  $\mathbb{E}^3$   $R$ -,

$P$ -, and  $H$ -pairs impose five constraints, a  $C$ -pair imposes four constraints, while  $S$ - and  $E$ -pairs impose three. However, in  $\mathbb{E}^2$   $S$ -,  $H$ -, and  $C$ -pairs are undefined, while  $E$ -pairs introduce no constraints but  $R$ - and  $P$ -pairs each introduce two.

### 5.7.1 The Chebyshev-Grübler-Kutzbach (CGK) Formula

Clearly,  $l$  unconstrained rigid links have  $d(l-1)$  relative DOF, given that one of the links is designated as a non-moving reference link. Any joint connecting two neighboring rigid bodies removes at least one relative DOF. If the joint removes no DOF then the bodies are not connected. If the joint removes 3 DOF in the plane, or 6 DOF in  $\mathbb{E}^3$  the two bodies are a rigid structure. Summarising this discussion, the DOF of a kinematic chain, relative to one fixed link in the chain, can be expressed as:

$$d(l-1) - \sum_{i=1}^j \mu_i - m = \text{DOF}, \quad (5.13)$$

where  $d = \dim(G')$ ,  $l$  is the number of links including the fixed link,  $\mu_i$  is the number of constraints imposed by the  $i^{\text{th}}$  joint,  $j$  is the number of joints, and  $m$  represents the number of idle DOF of the chain. The idle DOF of a chain are the number of independent single DOF motions that do not affect the transmission of motion from the input to the output links of the chain. Consider

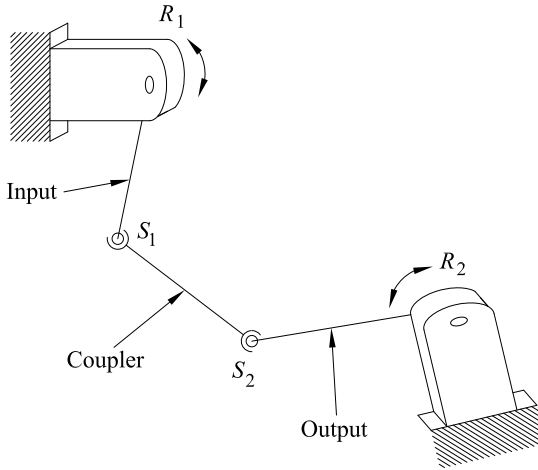

Figure 5.35: An  $RSSR$  spatial linkage has 1 DOF.

the  $RSSR$  linkage shown in Figure 5.35. The coupler is free to spin about its own longitudinal axis between  $S_1$  and  $S_2$ . The input link drives the linkage by rotating about axis  $R_1$ . The output link rotates about axis  $R_2$ . Clearly, the free spinning of the coupler does not contribute to the DOF of the chain. Hence, in this case,  $m = 1$ . This is an example in  $\mathbb{E}^3$  so  $d = 6$ . There are four links,

including the rigid frame to which  $R_1$  and  $R_2$  are fixed, thus  $l = 4$ . Each  $R$ -pair imposes  $\mu = 5$  constraints, while each  $S$ -pair imposes  $\mu = 3$ . Thus:

$$\begin{aligned} 6(4 - 1) - (2(5) + 2(3)) - 1 &= \\ 18 - 16 - 1 &= 1 \text{ DOF.} \end{aligned}$$

The idle DOF indeed exists, but does not contribute to the DOF of the  $RSSR$  chain. Equation (5.13) is known as the Chebyshev-Grübler-Kutzbach (CGK) formula. These three kinematicians independently developed it.

### 5.7.2 Examples

1. **Dump Truck Mechanism:** (simple closed chain). The lifting mechanism used to manipulate the dumping bed, or hopper, in a typical dump truck is essentially an  $RPRR$  four bar linkage, see Figure 5.36. Immediately we can write

$$\begin{aligned} d = 3, l = 4, \mu_i = 2, j = 4, m = 0, \\ d(l - 1) - \sum_{i=1}^j \mu_i - m = 3(4 - 1) - 4(2) - 0 = 9 - 8 = 1 \text{ DOF.} \end{aligned}$$

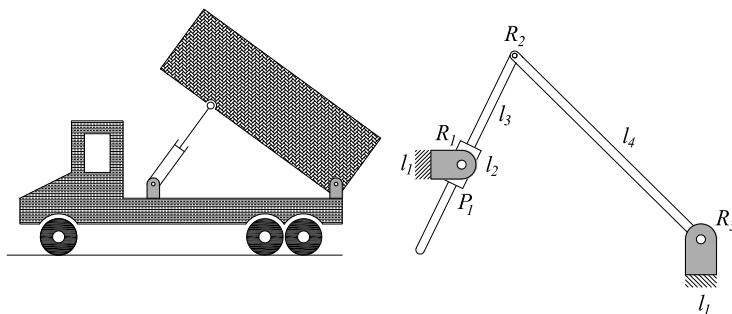

Figure 5.36: Dump-truck linkage is a planar RPRR mechanism.

2. **8-Bar Peaucellier Inversor:** (complex closed chain). The *Peaucellier inversor* is an 8-bar straight line generating mechanism with one relative DOF, see Figure 5.37 for example. The conditions that generate its unique kinematic geometry are that the lengths of each of  $l_3, l_4, l_5,$  and  $l_6$  are all equal, while the lengths of  $l_2$  and  $l_7$  are equal. These conditions create a symmetry which constrains the joint centres of  $R_{1,2}, R_{8,9}$  and  $R_5$  to always be collinear. Under these conditions the product of the distances between  $R_{1,2}$  and  $R_{8,9}$  and between  $R_{8,9}$  and  $R_5$  is a fixed constant. Moreover, the curves generated by joint centres  $R_{8,9}$  and  $R_5$  can be considered inverses. This result is made much more clear if another ground fixed revolute joint,

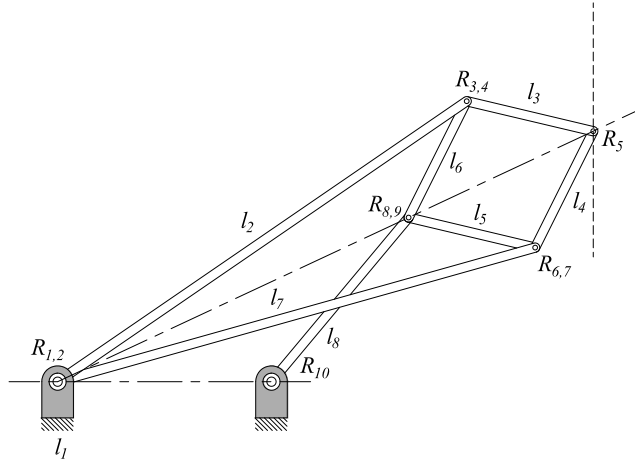

Figure 5.37: 8-bar Peaucellier inversor, a complex closed chain with 1 DOF.

$R_{10}$ , is added to the mechanism such that the distances between  $R_{1,2}$  and  $R_{10}$  and between  $R_{10}$  and  $R_{8,9}$  are equal. With this additional constraint joint centre  $R_{8,9}$  traces a circle while joint centre  $R_5$  traces a straight line. If the distance between  $R_{1,2}$  and  $R_{10}$  is not equal to the distance between  $R_{10}$  and  $R_{8,9}$  then revolute centre  $R_5$  can be made to trace an arbitrarily large radius arc. Its relative DOF are determined by

$$d = 3, \quad l = 8, \quad \mu_i = 2, \quad j = 10, \quad m = 0,$$

$$d(l - 1) - \sum_{i=1}^j \mu_i - m = 3(8 - 1) - 10(2) - 0 = 21 - 20 = 1 \text{ DOF.}$$

3. **3R Serial 3D Robot Arm:** The robot arm illustrated in Figure 5.38 is a spatial manipulator because the  $R_1$  and  $R_2$  axes are perpendicular intersecting lines, while the axes of  $R_2$  and  $R_3$  are parallel. Manipulators of this type are typically used for “pick-and-place” assembly operations. Intuition suggests that the arm should have 3 DOF. Confirming this we see

$$d = 6, \quad l = 4, \quad \mu_i = 5, \quad j = 3, \quad m = 0,$$

$$d(l - 1) - \sum_{i=1}^j \mu_i - m = 6(4 - 1) - 3(5) - 0 = 18 - 15 = 3 \text{ DOF.}$$

4. **Landing Gear With Over Centre Downlock:** The *mechanical advantage* of a linkage is the instantaneous ratio of output force, or torque, to the input force, or torque. This ratio is the negative of the reciprocal of the input/output angular velocity ratio. In the landing gear illustrated in

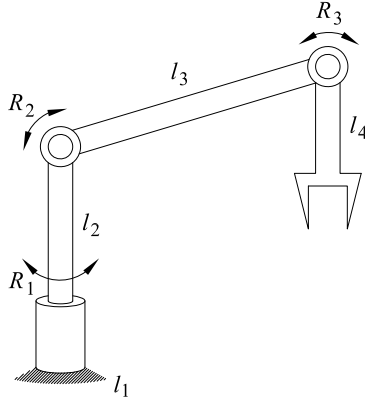

Figure 5.38: 3R serial spatial robot.

Figure 5.39 the input link is the active link  $l_4$ , driven by a motor spinning  $R_2$ . All other links in the chain are passive, and the output link is  $l_2$  which revolves freely about  $R_1$ . In this case, the mechanical advantage is defined to be

$$\frac{T_1}{T_2} = -\frac{\omega_2}{\omega_1}. \quad (5.14)$$

In the configuration shown in Figure 5.39 links 3 and 4 have just passed through a state of being on the same line. When links 3 and 4 are exactly aligned the mechanism is said to be in *toggle position*. In toggle position  $\omega_{l_4} = 0$  and hence  $\omega_2 = 0$ . In this state  $T_2 = 0$  and the mechanical advantage is infinite. But, the landing gear is just beyond toggle position, and is said to be *over centre* and locked. To push links 3 and 4 back through the toggle position requires a near infinite force to be applied to link  $l_2$  via the tire, while an infinitesimal torque applied by the motor at  $R_2$  will break the lock, pushing the linkage back through toggle. For this linkage, we have

$$d = 3, \quad l = 5, \quad \mu_i = 2, \quad j = 5, \quad m = 1,$$

$$d(l-1) - \sum_{i=1}^j \mu_i - m = 3(5-1) - 5(2) - 1 = 12 - 11 = 1 \text{ DOF}.$$

5. **Planar 3-Legged Platform:** Planar 3-legged platforms are used frequently in pick-and-place operations, see Figure 5.40. In this linkage, we have

$$d = 3, \quad l = 8, \quad \mu_i = 2, \quad j = 9, \quad m = 0,$$

$$d(l-1) - \sum_{i=1}^j \mu_i - m = 3(8-1) - 9(2) - 0 = 21 - 18 = 3 \text{ DOF}.$$

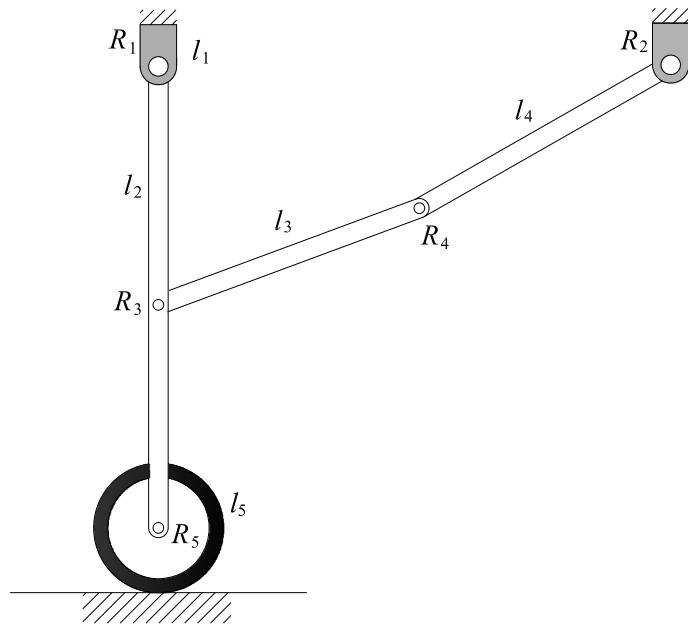

Figure 5.39: Landing gear downlock.

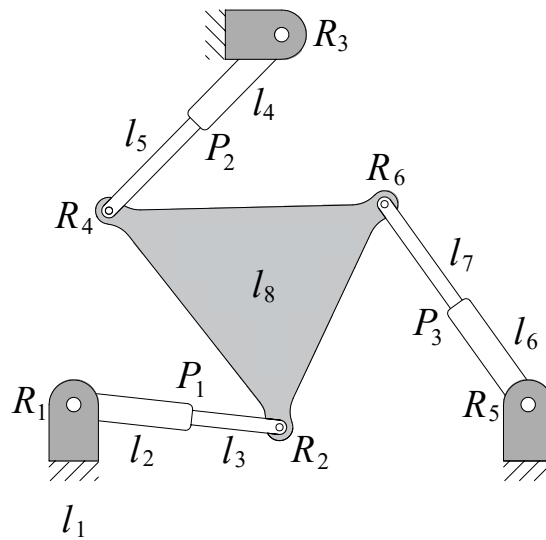

Figure 5.40: Planar 3-legged manipulator (complex closed chain).

6. **Gough-Stewart Flight Simulator Platform:** Gough-Stewart motion platforms are typically used as the motion bases for flight simulators, see Figures 5.41a and 5.41b. Hearing the term *robotic manipulator* usually

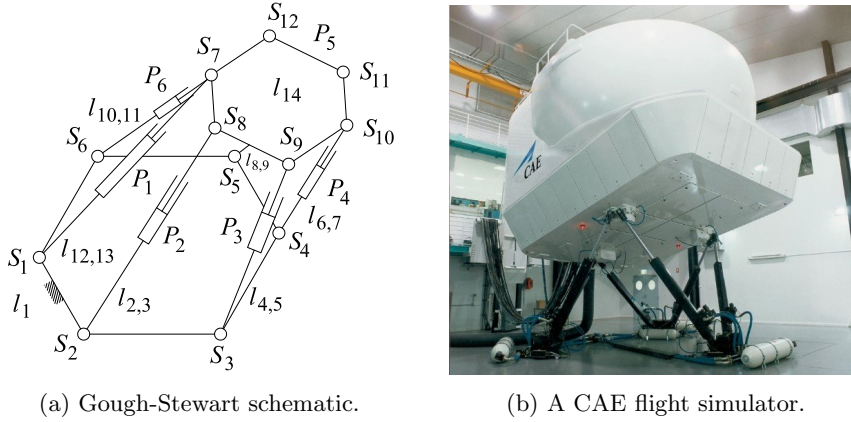

Figure 5.41: Gough-Stewart six-legged motion platform.

brings to mind the image of an arm consisting of links coupled by  $R$ - and  $P$ -pairs. These open kinematic chains are largely anthropomorphic in design. *Parallel manipulators* (i.e., a collection of serial manipulators connected at one end to the same fixed base and to a common moving link at the other), on the other hand, are somewhat less intuitive. Nonetheless, over the last fifty years this area has received substantial research. The usual paradigm is the *Stewart platform* type flight simulator designed by D. Stewart in 1965 [3] with the intention of simulating flight dynamics to train pilots. Yet earlier still, in 1949 a team in England, led by V.E. Gough, began the development of a *universal rig* to study tire wear under a variety of conditions determined by road surface, suspension, speed, and the change in the direction of the axis of rotation during cornering [4]. Because of the remarkable similarity between the two platforms, see Figure 5.42, this type is now usually called a *Gough-Stewart* platform, in recognition of Gough's earlier development of the six-legged parallel kinematic architecture.

Enumerating the links, joints, and constraints we obtain

$$\begin{aligned}
 d &= 6, \quad l = 14, \quad \mu_{P_i} = 5, \quad \mu_{S_i} = 3, \quad j = 18, \quad m = 6, \\
 d(l-1) - \sum_{i=1}^j \mu_i - m &= 6(14-1) - 6(5) - 12(3) - 6 = \\
 &= 78 - 30 - 36 - 6 = 6 \text{ DOF.}
 \end{aligned}$$

The six idle degrees of freedom associated with the  $R$ -pairs in between a pair of  $S$ -pairs are the free spinning about the longitudinal axis of the  $P$ -pairs. This has led to universal joints, see Figure 5.43,  $U$ -pairs, which is an assembly of two orthogonal intersection revolute axes, being used on either the base or moving platform in practice instead of  $S$ -pairs making

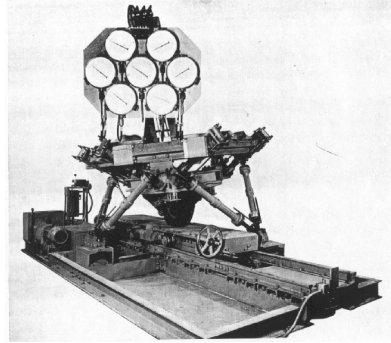

(a) Gough's Universal Rig.

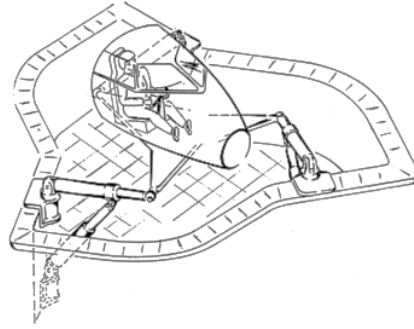

(b) Stewart's original conceptual flight simulator platform.

Figure 5.42: Origin of the term “Gough-Stewart”.

each leg an *UPS* chain, which eliminates the idle degrees of freedom.

Figure 5.43: A universal joint, or *U*-pair.

7. **Bench Vice:** The bench vice presents some interesting diversion. At first glance, it is planar, so we immediately set  $d = 3$  without hesitation:

$$d = 3, l = 3, \mu_i = 2, j = 3, m = 0,$$

$$\Rightarrow d(l - 1) = \sum_{i=1}^j \mu_i - m = 3(3 - 1) - 3(2) - 0 = 6 - 6 = 0 \text{ DOF}$$

Experience insists that a bench vice has 1 DOF! This seeming anomaly is an artifact of representation. The *R*- and *H*- axes are parallel while the translation direction of the *P*-pair is also parallel, see Figures 5.44b and 5.44a.

The *P*- and *R*-pairs are kinematically equivalent to a single *C*-pair. Moreover, the axis of the *H*-pair is parallel to the axis of the *C*-pair. Therefore, the dimension of the motion sub-group represented by the common bench

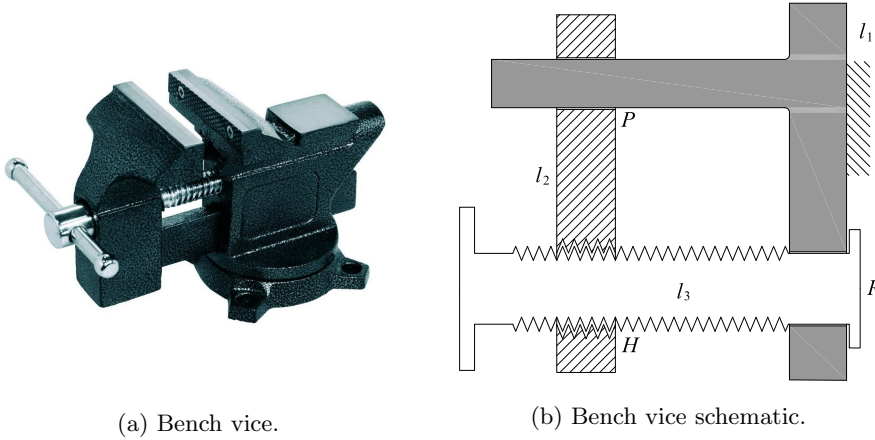

(a) Bench vice.

(b) Bench vice schematic.

Figure 5.44: Typical bench vice.

vice is  $d = 2$ , **not**  $d = 3$ . Thus:

$$d = 2, l = 3, \mu_i = 1, j = 3, m = 0,$$

$$d(l-1) - \sum_{i=1}^j \mu_i - m = 2(3-1) - 3(1) - 0 = 4 - 3 = 1 \text{ DOF.}$$

So one must be careful blindly applying the CGK-formula. Still, note that we had to treat the  $C$ -pair as a  $P$ -pair and an  $R$ -pair separately. Be warned though that the sub-group dimension argument is controversial.

The geometric model of the CGK-formula is incomplete. Certain geometric mechanism properties are not modeled by it. As a result, there are many mechanisms with 1 DOF that are not identified by the CGK-formula. Such seemingly anomalous linkages are said to be *over-constrained*. The Bennett  $4R$  Linkage [5], is one of the best known examples of an over-constrained mechanism, as illustrated in Figure 5.45. Opposite links are twisted by the same angle and have the same length. Twist angles  $\tau_1$  and  $\tau_2$  are proportional to lengths  $a_1$  and  $a_2$ . Similarly,  $\tau_3$  and  $\tau_4$  are proportional to  $a_3$  and  $a_4$ . The proportionality is governed by:

$$\frac{a_1}{\sin \tau_1} = \pm \frac{a_2}{\sin \tau_2}.$$

Using the CGK-formula we get:

$$d = 6, l = 4, \mu_i = 5, j = 4, m = 0,$$

$$d(l-1) - \sum_{i=1}^j \mu_i - m = 6(4-1) - 4(5) - 0 = 18 - 20 = -2 \text{ DOF.}$$

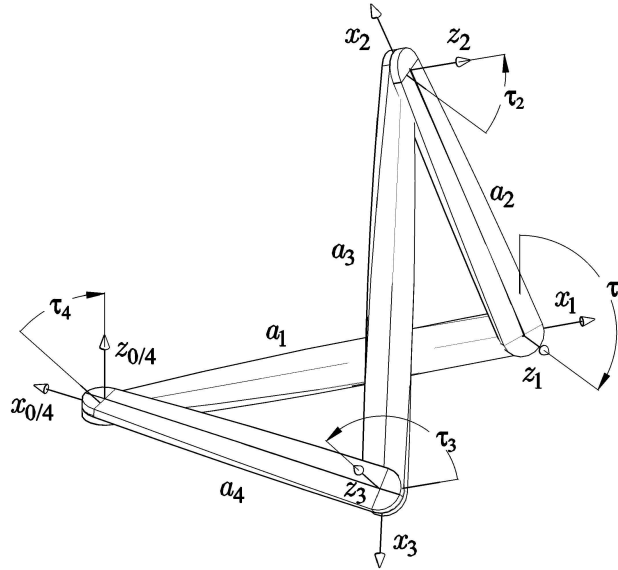

Figure 5.45: A Bennett mechanism.

The CGK-formula predicts a hyper-static over-constrained structure, when the Bennett mechanism actually has 1 DOF. Refining the CGK-formula to model such geometric conditions is still an open problem.

## 5.8 A Note on the Axes of $R$ -Pairs and $P$ -pairs

The axis of an  $R$ -pair is a line through the invariant centre point of rotation perpendicular to the plane of motion. But it does not make sense, from a mechanical engineering point of view, to speak about the axis of a  $P$ -pair in the same way, as no real points in  $\mathbb{E}^2$  are invariant under a translation.  $P$ -pairs permit translations parallel to one direction. One such translation, indicated by  $\tau$ , is shown in Figure 5.46. Mathematically, the axis of a  $P$ -pair could be described as the line at infinity,  $N_\infty$ , of all planes normal to the direction of  $\tau$ . This is illustrated in Figure 5.46 where  $\Sigma$  is the plane containing the  $P$ -pair,  $\tau$  is a particular translation effected by the  $P$ -pair,  $N_1$  and  $N_2$  are normal to  $\Sigma$ , and  $\Omega$  is the plane at infinity. The two planes  $\Sigma$  and  $\Omega$  intersect in  $L_\infty$ . Lines in the direction of  $\tau$  intersect  $L_\infty$  in point  $P_1$ . Lines normal to  $\tau$  in  $\Sigma$ , indicated by  $\eta$ , intersect  $L_\infty$  in  $P_2$ . The line  $N_\infty$  is the intersection of all planes normal to  $\Sigma$  and parallel to  $\eta$ . Moreover, all normals to  $\Sigma$ ,  $N_1$ , and  $N_2$  being two of them, intersect  $N_\infty$  in the point  $P_3$ . The join of  $P_2$  and  $P_3$  is  $N_\infty$ , which is the axis of the particular prismatic joint. In other words, the axis of a  $P$ -pair is the absolute polar line to the point at infinity of the direction of translation. More on polar lines when we discuss projective geometry. Regardless,  $P$ -pairs would

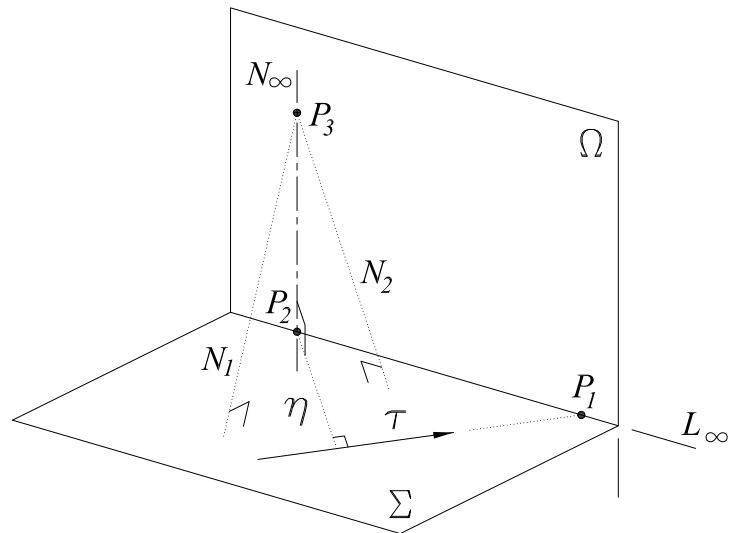

Figure 5.46: P-pair axis.

be impossible to manufacture if they had no longitudinal axis of symmetry to establish the direction of translation, i.e. no longitudinal centreline. One must not confuse this centreline with the joint axis, which is, for mechanical reasons, inaccessible.



# Bibliography

- [1] H.S.M. Coxeter and W.O.J. Moser. *Generators and Relations for Discrete Groups*, 4<sup>th</sup> edition. Springer-Verlag, Berlin, Germany, 1980.
- [2] H.S.M. Coxeter. *Introduction to Geometry*, 2<sup>nd</sup> edition. University of Toronto Press, Toronto, On., Canada, 1969.
- [3] D. Stewart. “A Platform With Six Degrees of Freedom”. *Proc. Instn. Mech. Engrs.*, vol. 180, Part 1, no. 15: pages 371–378, 1965.
- [4] V.E. Gough. “Discussion in London: Automobile Stability, Control, and Tyre Performance”. *Proc. Automobile Division, Institution of Mech. Engrs.*, pages 392–394, 1956.
- [5] G.T. Bennett. “The Skew Isogram Mechanism”. *Proc. of the London Mathematical Society*, 13:151–173, 1913.

